

INSTALLATION

TRIFAB® VG

SHEAR BLOCK ASSEMBLY

- TRIFAB VG 450
- TRIFAB VG 451
- TRIFAB VG 451T

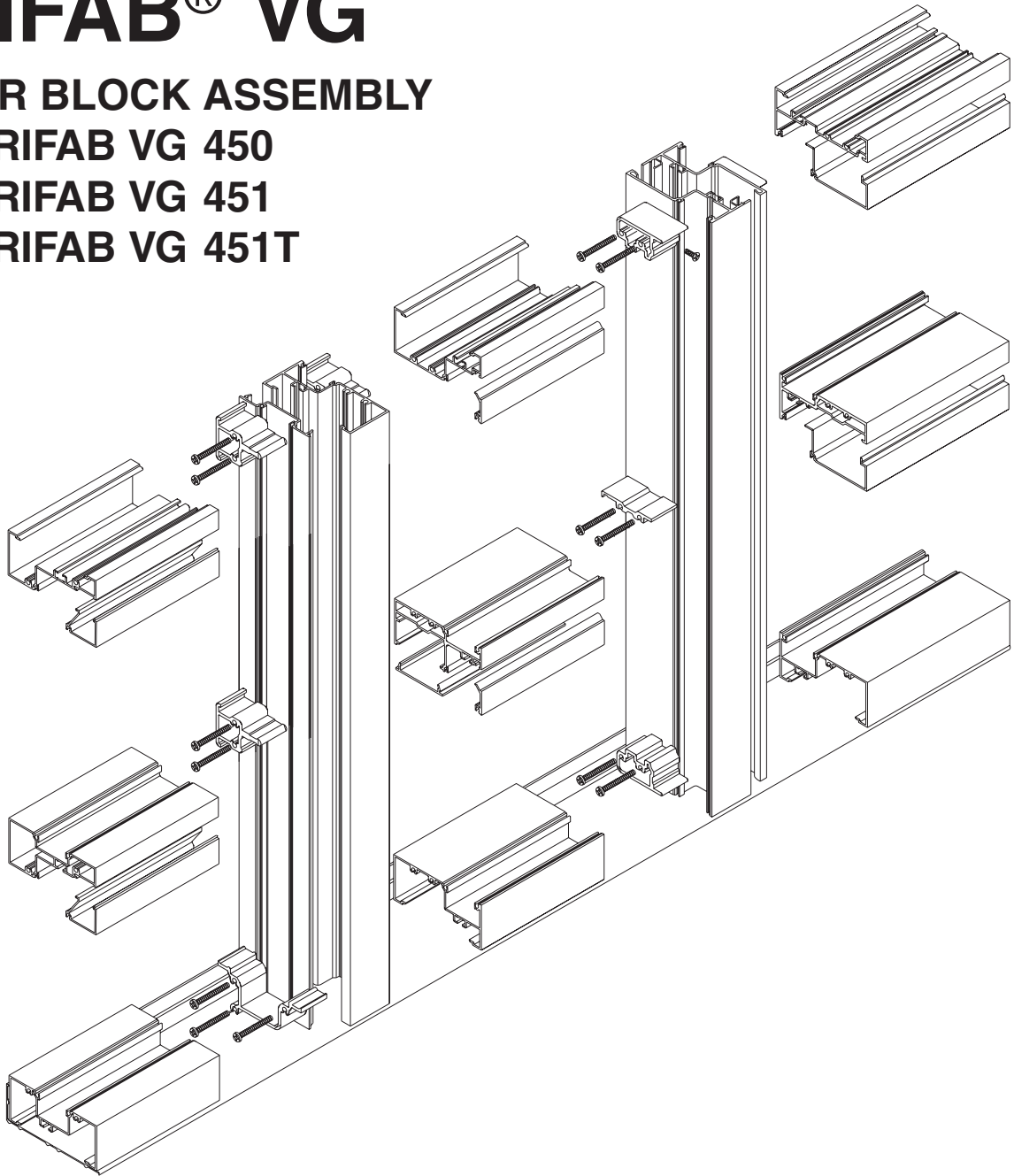

INSTRUCTIONS

INSTALLATION INSTRUCTIONS

CONTENTS

These instructions show the general installation sequence and procedure for typical installations. They supplement the shop details and notations on installation and glazing.

<u>SECTION</u>	<u>PAGE</u>	
I	3-4	GENERAL NOTES * MATERIAL HANDLING, STORING & PROTECTION OF ALUMINUM * GENERAL INSTALLATION NOTES
II	5-7	BASIC FRAMING DETAILS
III	8-12	TRIFAB VG 450 FRAME FABRICATION & ASSEMBLY
IV	13-16	TRIFAB VG 450 DOOR JAMB SIDELITE FABRICATION & ASSY.
V	17-22	TRIFAB VG 451/451T FRAME FABRICATION & ASSY.
VI	23-26	TRIFAB VG 451/451T DOOR JAMB SIDELITE FABRICATION & ASSY.
VII	27-32	INSTALLATION
VIII	33	GLAZING ADAPTERS
IX	34-35	GLAZING
X	36-42	OPTIONAL CORNERS
XI	43	EXPANSION MULLION
XII	43	STEEL REINFORCING
XIII	44-45	SIDELITE BASE

NOTE:

FABRICATION, INSTALLATION & GLAZING ARTWORK DEPICTS TYPICAL 1" CENTER GLAZED MEMBERS. ALL 1/4" INFILL AND 1" FRONT, BACK AND MULTI-PLANE APPLICATIONS ARE SIMILAR UNLESS OTHERWISE NOTED. OUTSIDE GLAZING IS TYPICALLY SHOWN UNLESS OTHERWISE NOTED.

SECTION I - GENERAL NOTES

HANDLING, STORING, AND PROTECTION OF ALUMINUM

The material must be protected against damage. The following precautions are recommended to assure early acceptance of your products and workmanship.

- A. **HANDLE CAREFULLY** - Don't drop from the truck. Stack with adequate separation so material will not rub together. Store off ground. Protect against elements and other construction trades. Wear hand protection to prevent injury due to sharp edges of cut extrusions.
- B. **KEEP MATERIAL AWAY FROM WATER, MUD AND SPRAY** - Prevent cement, plaster, or other materials from damaging the finish.
- C. **PROTECT THE MATERIALS AFTER ERECTION** - Protect by wrapping with Kraft paper or by erecting Visqueen or canvas splatter screen. Cement, plaster, terrazzo, other alkaline solutions and acid based materials used to clean masonry are very harmful to the finish and should be removed with water and mild soap IMMEDIATELY.

GENERAL INSTALLATION NOTES

The following practices are recommended for all installations:

- A. **CHECK SHOP DRAWINGS, INSTALLATION INSTRUCTIONS and GLAZING INSTRUCTIONS** to become thoroughly familiar with the project. The SHOP DRAWINGS take precedence and include specific details for the project. The INSTALLATION INSTRUCTIONS are of a general nature and cover most common conditions.
- B. All materials are to be **INSTALLED PLUMB, LEVEL, AND TRUE**.
- C. All work should start from bench marks and/or column lines as established by the ARCHITECTURAL DRAWINGS and the GENERAL CONTRACTOR. Check mullion spacing from both ends of masonry opening to prevent dimensional build-up of day light opening.
- D. Make certain that construction which will receive your materials is in accordance with the contract documents. If not, notify the GENERAL CONTRACTOR IN WRITING and resolve differences before proceeding with your work.
- E. Isolate all aluminum to be placed directly in contact with uncured masonry or incompatible materials with a heavy coat of zinc chromate or bituminous paint.
- F. Check all materials on arrival for quantity and be sure you have everything required to begin installation.
- G. Sealants must be compatible with all materials with which they have contact, including other sealant surfaces. Consult with sealant manufacturer for recommendations relative to joint size, shelf life, compatibility, priming, tooling, adhesion, etc.
- H. **FASTENING** - "Fastening" means any method of securing one part to another or to adjacent materials. These instructions specify only those fasteners used within the system. Due to varying perimeter conditions and job performance requirements, anchor fasteners are not specified in these instructions. For anchor fastening, refer to the Shop Drawings or consult the fastener supplier.
- I. **CHECK OPENINGS** - Make certain that the opening which will receive your materials is in accordance with the contract documents. If not, notify the General Contractor *in writing* and resolve differences before proceeding with your work.
- J. **BUILDING CODES** - Glass and glazing codes governing the design and use of products vary widely. Kawneer does not control the selection of product configurations, operating hardware, or glazing materials, and assumes no responsibility for these design considerations. It is the responsibility of the owner, specifier, architect, general contractor and the installer to make these selections in strict conformance with all applicable codes.
- K. **EXPANSION JOINTS** - Expansion joints and perimeter seals shown in these instructions and in the shop drawings are shown at normal size. Actual dimensions may vary due to perimeter conditions and /or difference in metal temperature between the time of fabrication and time of installation. For example, a 12 foot unrestrained length of aluminum extrusion can expand or contract 3/32" over a 50° F temperature change. Any movement potential should be accounted for at the time of installation.

SECTION I - GENERAL NOTES

- L. FIELD TESTING** - It is recommended that a Water Hose Test be conducted once a sufficient portion of the framing is installed, glazed and caulked to ensure proper installation. The Water Hose test shall be conducted in accordance with AAMA 501.2. In addition, larger projects should have periodic Water Hose Tests as additional precautionary measures.

- M. GASKET INVENTORY ROTATION** - These high quality rubber extrusions are coated with silicone lubricant. Silicone will dry over time leaving a white “chalky” residue. Please rotate your stock “FIRST IN - FIRST OUT”. If the rubber becomes dry, you may use water ONE TIME to reconstitute the silicone, after that, use a soap water solution.

SECTION II - BASIC FRAMING DETAILS

The Shear Block System is a fabrication and erection method that permits the pre-assembly of multi-lite units in the shop or at the job site. These units are joined with shear blocks and installed as an assembled unit in the opening on top of the sill flashing.

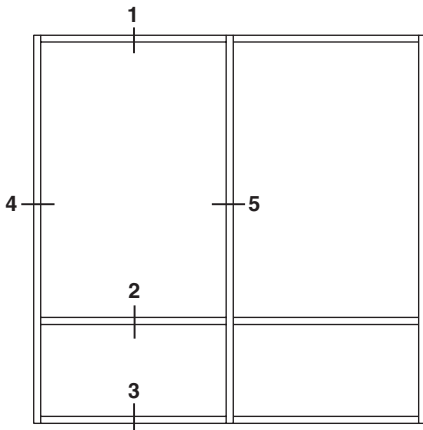

ELEVATION IS NUMBER KEYED TO DETAILS

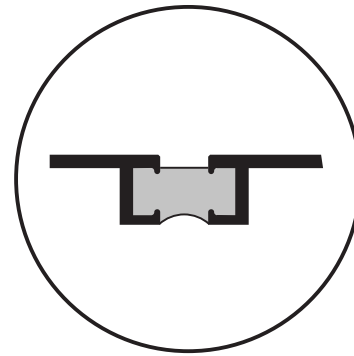

TRIFAB® VG 451T
THERMALLY BROKEN MEMBERS

CENTER

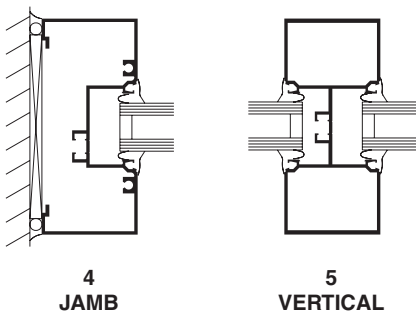

4
JAMB

5
VERTICAL

1
HEAD

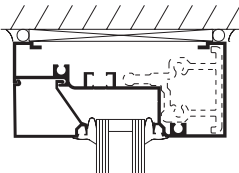

2
HORIZONTAL

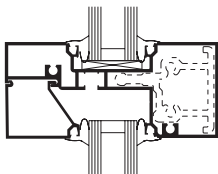

3
SILL

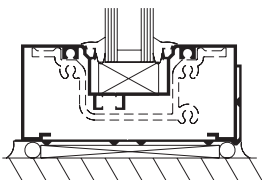

FRONT

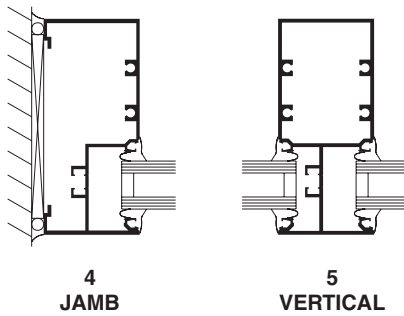

4
JAMB

5
VERTICAL

1
HEAD

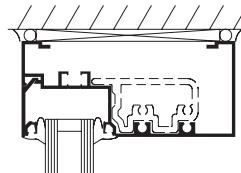

2
HORIZONTAL

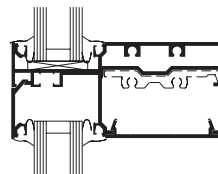

3
SILL

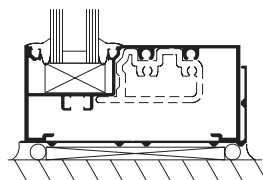

BACK

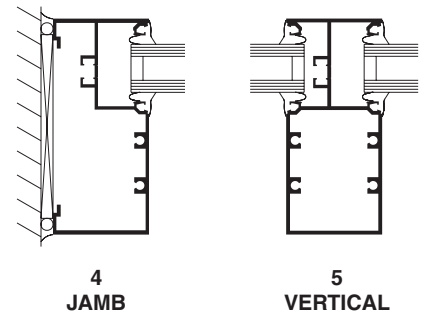

4
JAMB

5
VERTICAL

1
HEAD

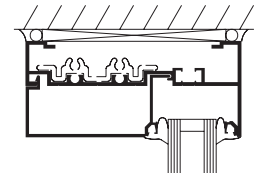

2
HORIZONTAL

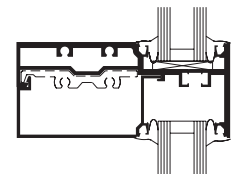

3
SILL

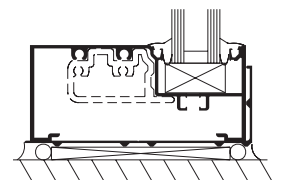

SECTION II - BASIC FRAMING DETAILS

INSIDE GLAZED DETAILS SHOWN

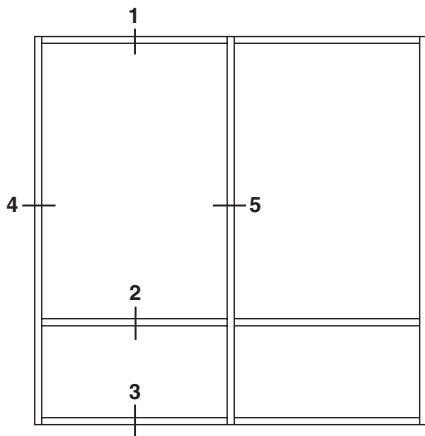

ELEVATION IS NUMBER KEYED TO DETAILS

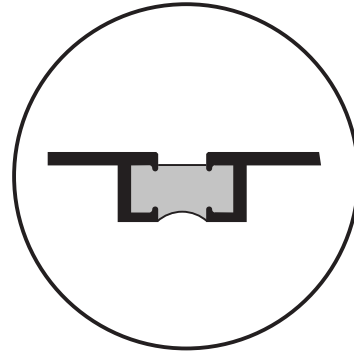

TRIFAB® VG 451T
THERMALLY BROKEN MEMBERS

CENTER

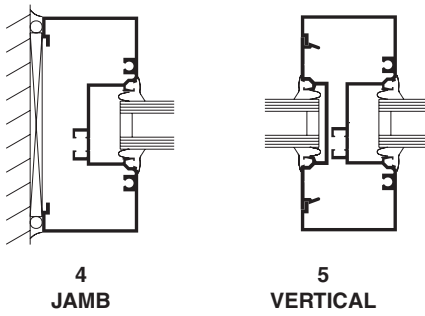

1 HEAD

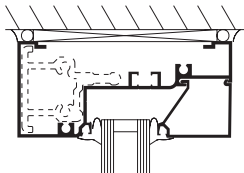

2 HORIZONTAL

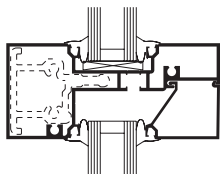

3 SILL

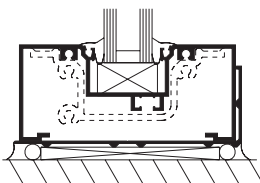

FRONT

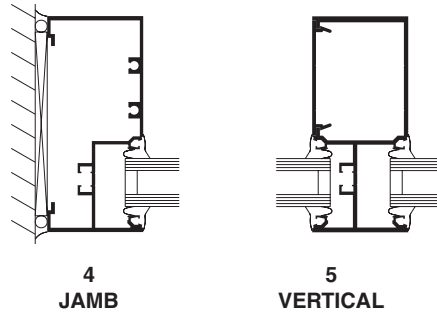

1 HEAD

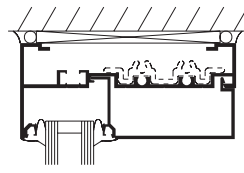

2 HORIZONTAL

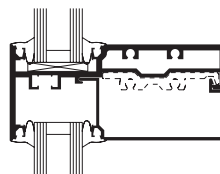

3 SILL

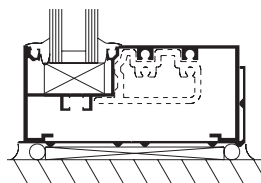

BACK

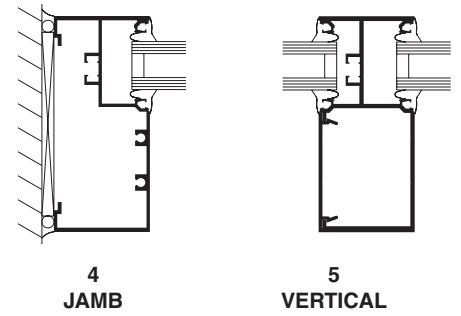

1 HEAD

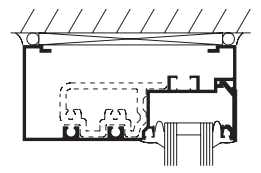

2 HORIZONTAL

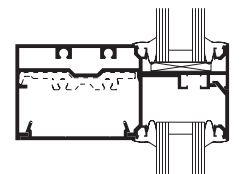

3 SILL

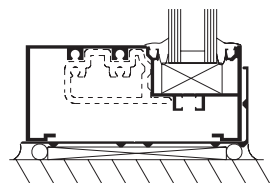

SECTION II - BASIC FRAMING DETAILS

MULTI-PLANE DETAILS SHOWN

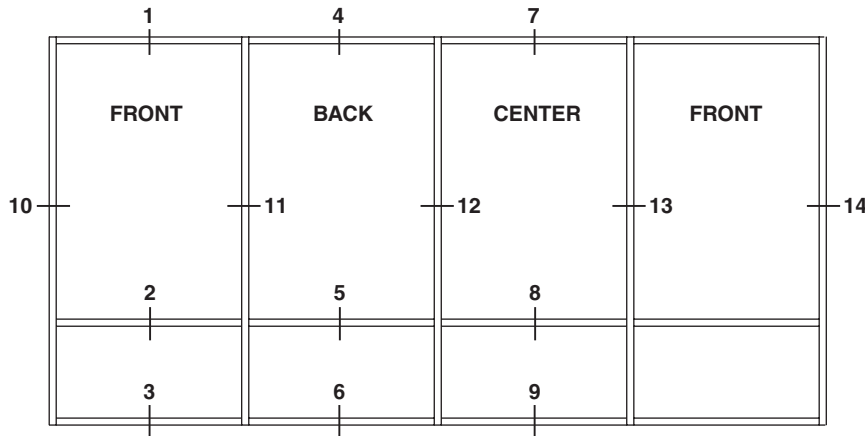

ELEVATION IS NUMBER KEYED TO DETAILS

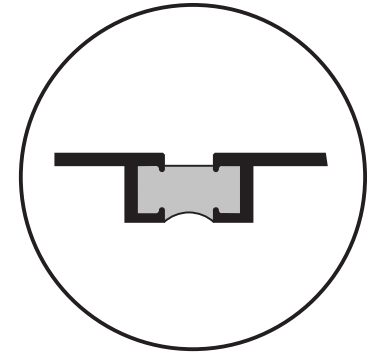

TRIFAB® VG 451T
THERMALLY BROKEN MEMBERS

MULTI-PLANE

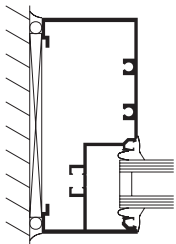

10
JAMB

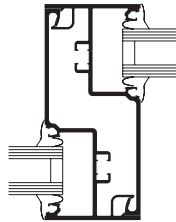

11
VERTICAL

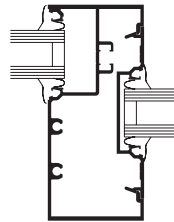

12
VERTICAL

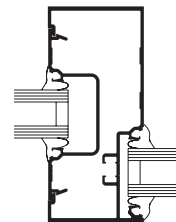

13
VERTICAL

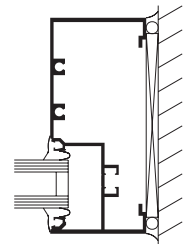

14
JAMB

FRONT

1
HEAD

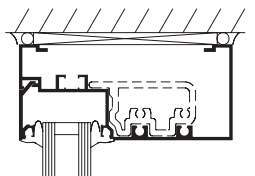

2
HORIZONTAL

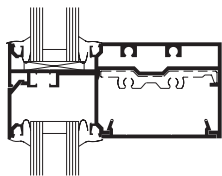

3
SILL

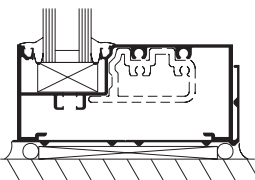

BACK

4
HEAD

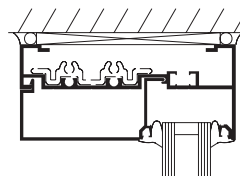

5
HORIZONTAL

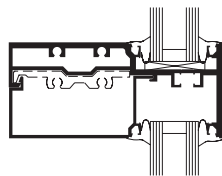

6
SILL

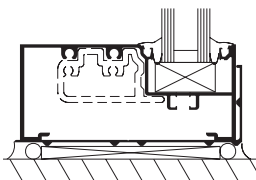

CENTER

7
HEAD

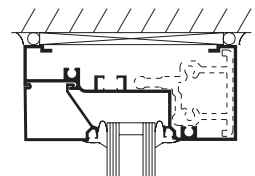

8
HORIZONTAL

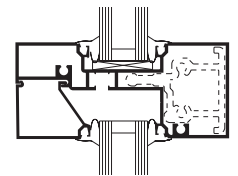

9
SILL

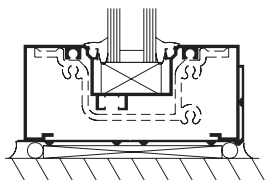

SECTION III - FRAME FABRICATION & ASSEMBLY

SHEAR BLOCK PREPS FOR CENTER OPTION

Step A: Measure the opening to determine length of vertical and horizontal framing members. For all units that require sill flashing, allow a minimum of **1/8"** for standard flashing and **7/16"** for high-performance flashing when measuring vertical lengths. Allow 1/4" min. clearance at the head, sill, and each jamb to facilitate installation and provide space for caulking. If job conditions are uncertain, or masonry openings are irregular, or if high-performance flashing is used, allow extra clearance to accommodate construction tolerance.

Step B: Cut vertical members to required length (Frame Height). At desired horizontal locations drill the proper holes in the verticals for attachment of the shear blocks, as shown below.

Step C: Attach shear blocks to vertical mullions using #28-400 (#10 x 1-19/32" P.H.) screws as required.

TRIFAB VG 450 (CENTER OPTION)

PLACE JIG ONTO MULLION AS SHOWN BELOW

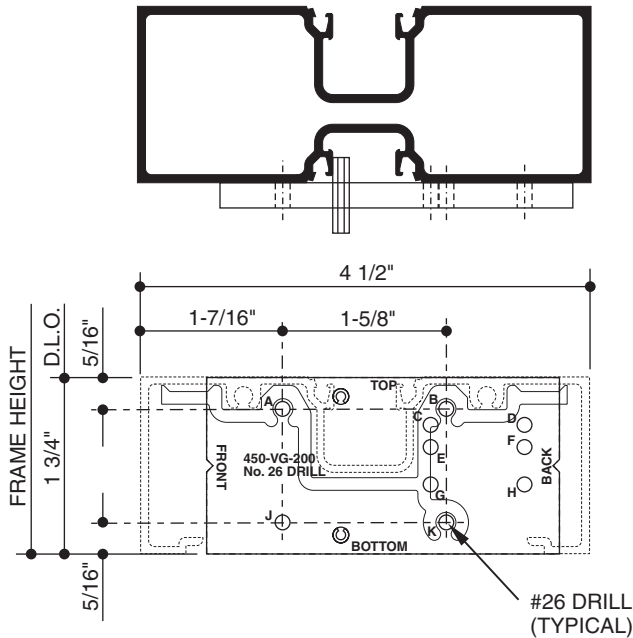

OUTSIDE GLAZED (STOPS DOWN)



HEAD PREP = HOLES (A, B, K)

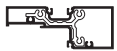

HORIZONTAL PREP = HOLES (A, B, K)

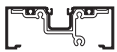

SILL PREP = HOLES (A, B, K)

OUTSIDE GLAZED (STOPS UP)



HEAD PREP = HOLES (B, J, K)



HORIZONTAL PREP = HOLES (B, J, K)



SILL PREP = HOLES (B, J, K)

TRIFAB VG 450 (CENTER OPTION)

PLACE JIG ONTO MULLION AS SHOWN BELOW

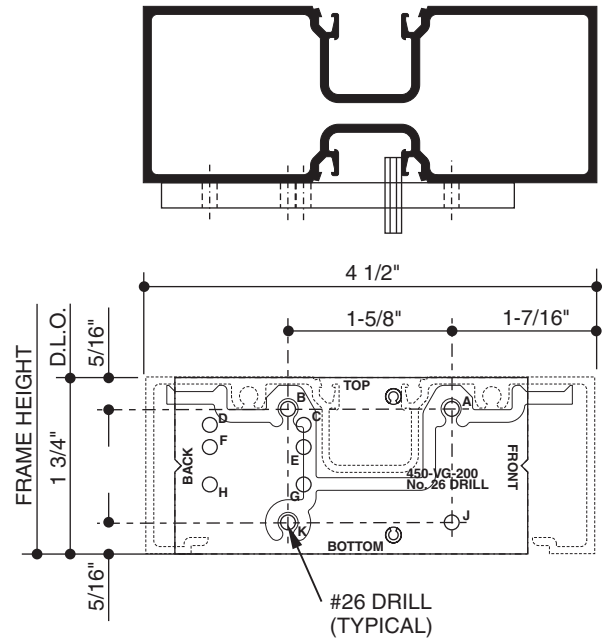

INSIDE GLAZED



HEAD PREP = HOLES (A, B, K)



HORIZONTAL PREP = HOLES (A, B, K)

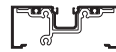

SILL PREP = HOLES (A, B, K)

SECTION III - FRAME FABRICATION & ASSEMBLY

SHEAR BLOCK PREPS FOR CENTER OPTION

Step D: Cut horizontals to length = Daylight Opening, (Glass stops should be D.L.O. - 1/16").

Step E: Fabricate head, sill, and intermediate horizontals by drilling and countersinking for #10 F.H. screws.

HEAD

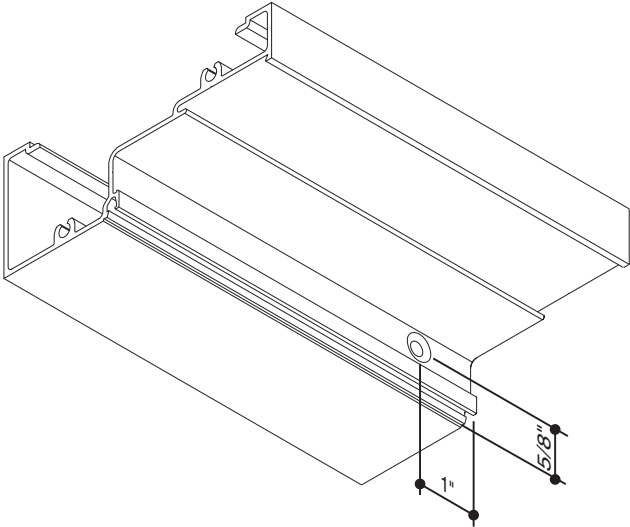

HORIZONTAL

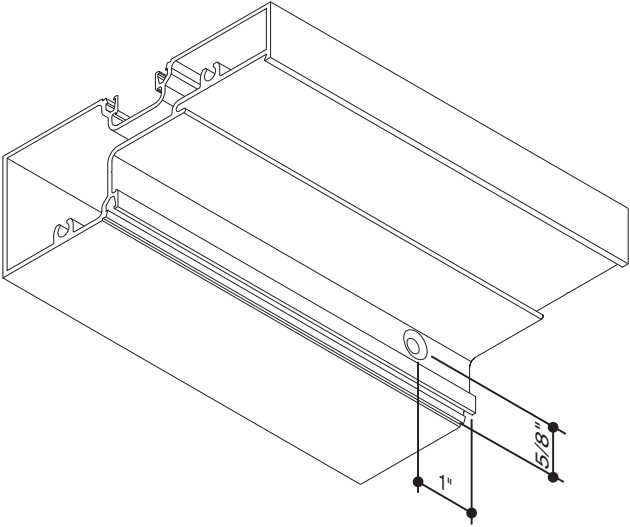

SILL

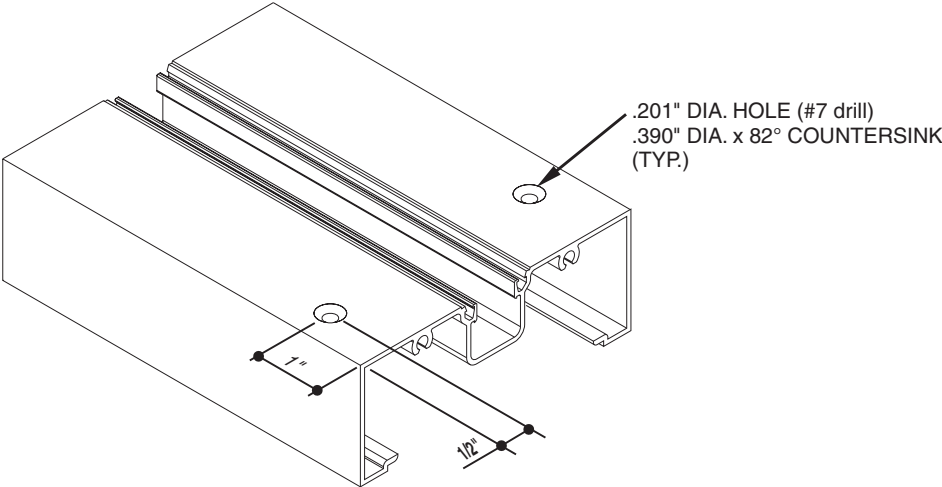

SECTION III - FRAME FABRICATION & ASSEMBLY

SHEAR BLOCK PREPS FOR FRONT or BACK OPTION

Step A: Measure the opening to determine length of vertical and horizontal framing members. For all units that require sill flashing, allow a minimum of **1/8"** for standard flashing and **7/16"** for high-performance flashing when measuring vertical lengths. Allow 1/4" min. clearance at the head, sill, and each jamb to facilitate installation and provide space for caulking. If job conditions are uncertain, or masonry openings are irregular, or if high-performance flashing is used, allow extra clearance to accommodate construction tolerance.

Step B: Cut vertical members to required length (Frame Height). At desired horizontal locations drill the proper holes in the verticals for attachment of the shear blocks, as shown below.

Step C: Attach shear blocks to vertical mullions using #28-400 (#10 x 1-19/32" P.H.) screws as required.

TRIFAB VG 450 (FRONT OPTION)

PLACE JIG ONTO MULLION AS SHOWN BELOW

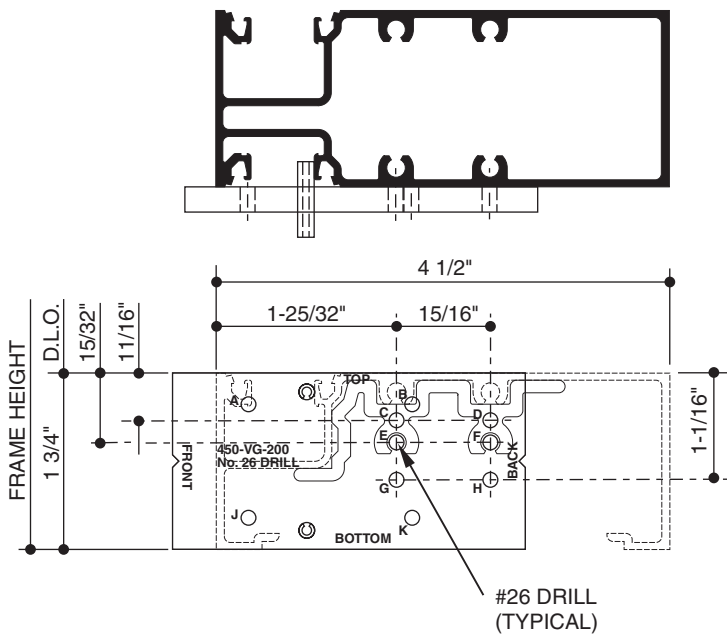

OUTSIDE GLAZED



HEAD PREP = HOLES (G, H)



HORIZONTAL PREP = HOLES (E, F)



SILL PREP = HOLES (E, F)

INSIDE GLAZED



HEAD PREP = HOLES (C, D)



HORIZONTAL PREP = HOLES (E, F)



SILL PREP = HOLES (E, F)

TRIFAB VG 450 (BACK OPTION)

PLACE JIG ONTO MULLION AS SHOWN BELOW

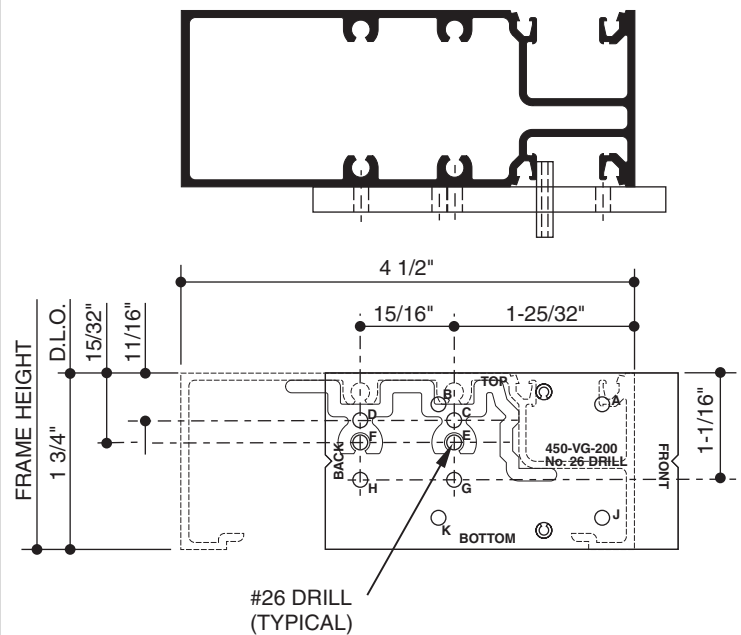

OUTSIDE GLAZED



HEAD PREP = HOLES (C, D)



HORIZONTAL PREP = HOLES (E, F)



SILL PREP = HOLES (E, F)

INSIDE GLAZED



HEAD PREP = HOLES (G, H)



HORIZONTAL PREP = HOLES (E, F)



SILL PREP = HOLES (E, F)

SECTION III - FRAME FABRICATION & ASSEMBLY

SHEAR BLOCK PREPS FOR FRONT OR BACK OPTIONS

Step D: Cut horizontals to length = Daylight Opening, (Glass Stops should be D.L.O. - 1/16").

Step E: Fabricate head and sill by drilling and countersinking for #10 F.H. screws.

**FRONT - INSIDE GLAZED
OR
BACK - OUTSIDE GLAZED**

**FRONT - OUTSIDE GLAZED
OR
BACK - INSIDE GLAZED**

HEAD

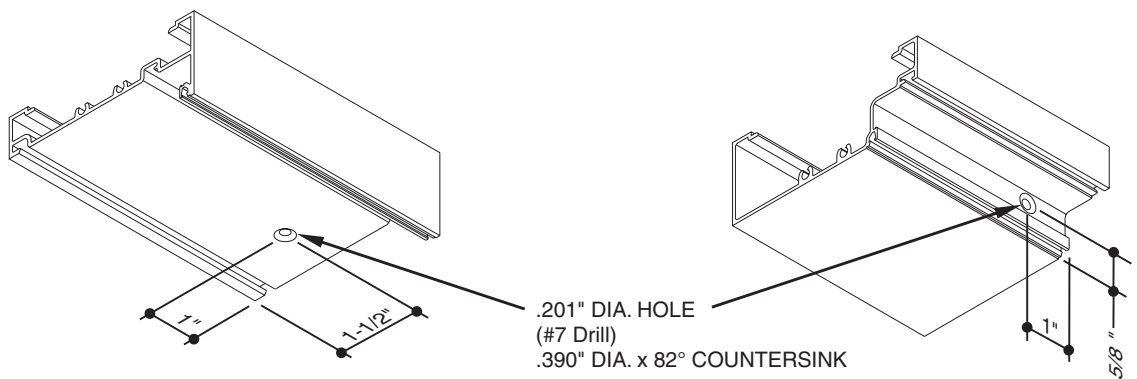

SILL

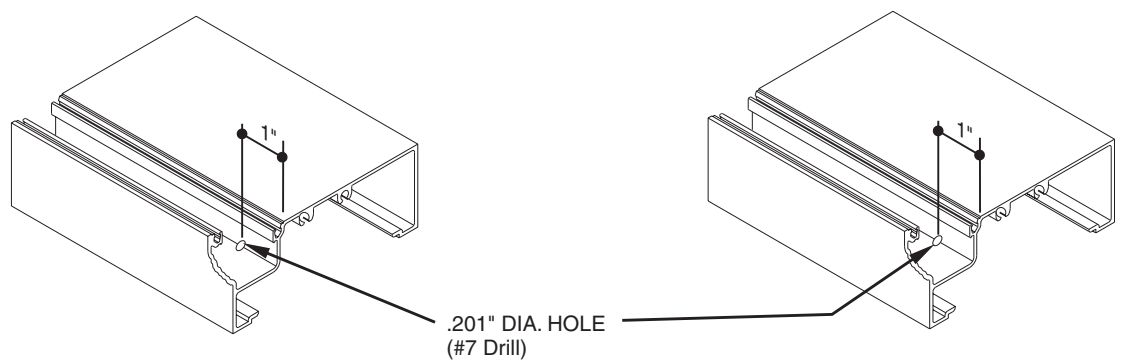

SECTION III - FRAME FABRICATION & ASSEMBLY

STEP A:

Hold fabricated horizontal member in place over shear block and tight against vertical member. Then match drill tap hole in shear block with #26 drill (.147") slightly offset to **Vertical Mullion Side** of countersunk hole in the horizontal so as to pull the joint tight when assembled as shown below. (See Figure 1)

NOTE: FOR FRONT OR BACK INTERMEDIATE HORIZONTALS

Hold fabricated horizontal member in place over shear block and tight against vertical member. Then match drill tap hole in horizontal with #26 drill (.147") slightly offset to **D.L.O. Side** of hole in the shear block so as to pull the joint tight when assembled as shown below. (See Figure 2)

STEP B:

Apply sealant to the ends of all horizontal members, shear blocks and into reglets as shown below.

STEP C:

Attach horizontal members to shear blocks with fasteners provided in shear block packages.

STEP D:

Continue procedure above until entire frame is assembled.

STEP E:

Install flat fillers into head, jamb and sill at perimeter anchor locations.

Crimp material to prevent filler plate from sliding. Perimeter anchors should be located within 6" on each side of vertical mullions and 24" O.C. between vertical mullions.

NOTE:

IT IS IMPORTANT THAT THE INSTALLER APPLY SEALANT TO SHEAR BLOCKS, ENDS OF ALL HORIZONTAL MEMBERS AND GLAZING REGLETS AS SHOWN TO ENSURE GOOD SEAL.

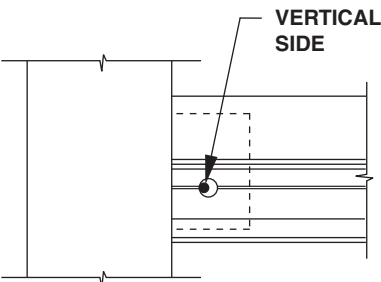

FIGURE 1
FOR CENTER OPTION
INTERMEDIATE HORIZONTALS

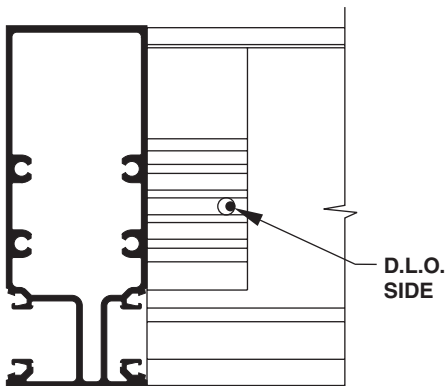
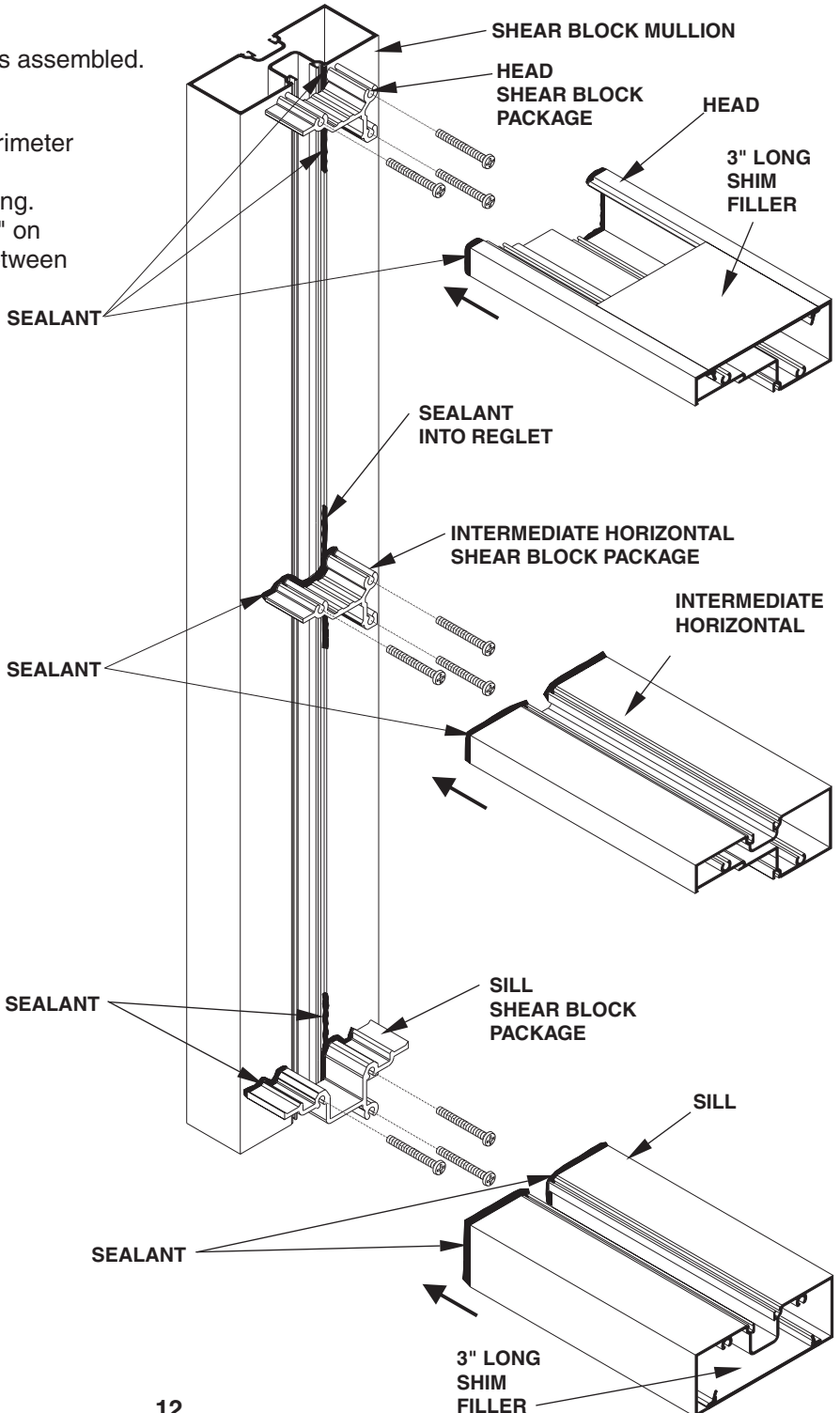

FIGURE 2
FOR FRONT OR BACK OPTION
INTERMEDIATE HORIZONTALS



SECTION IV - DOOR JAMB SIDELITE FABRICATION & ASSEMBLY

SHEAR BLOCK PREPS

Apply the same shear block preps on Door Jambs that were applied to vertical mullions, allowing for shim space and sill flashing at sill, as shown below.

Step A: At desired horizontal locations drill the proper holes in the door jambs for attachment of the shear blocks, as shown below.

Step B: Attach shear blocks to door jambs using #28-400 (#10 x 1-19/32" P.H.) screws as required.

TRIFAB VG 450 (FRONT OPTION)

PLACE JIG ONTO MULLION AS SHOWN BELOW

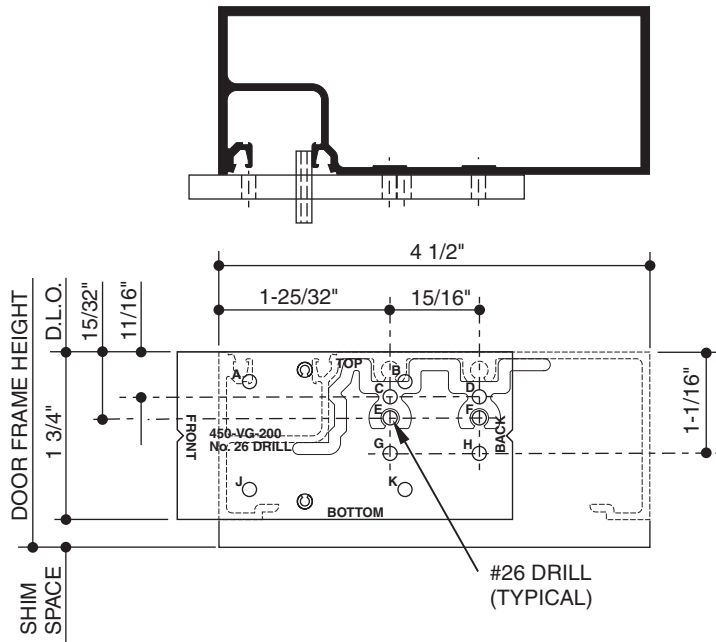

TRIFAB VG 450 (BACK OPTION)

PLACE JIG ONTO MULLION AS SHOWN BELOW

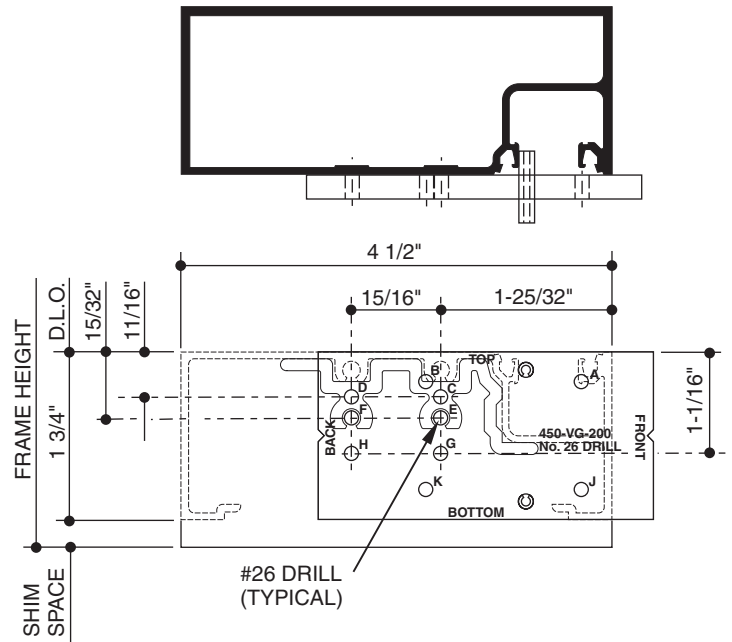

TRIFAB VG 450 (CENTER OPTION)

PLACE JIG ONTO MULLION AS SHOWN BELOW

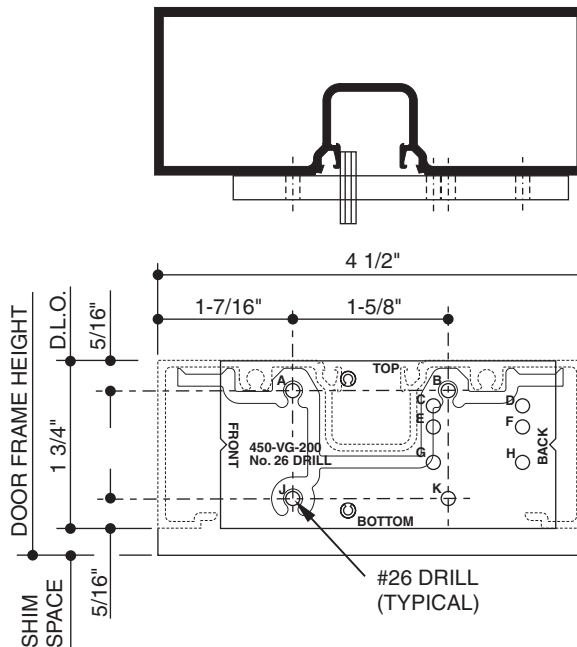

SECTION IV - DOOR JAMB SIDELITE FABRICATION & ASSEMBLY

SHEAR BLOCK PREPS FOR CENTER OPTION

Step C: Cut horizontals to length = Daylight Opening, (Glass stops should be D.L.O. - 1/16").

Step D: Fabricate head, sill, and intermediate horizontals by drilling and countersinking for #10 F.H. screws.

HEAD

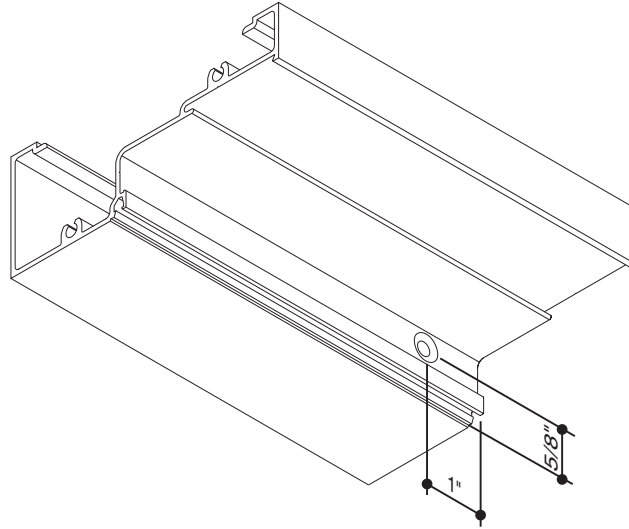

HORIZONTAL

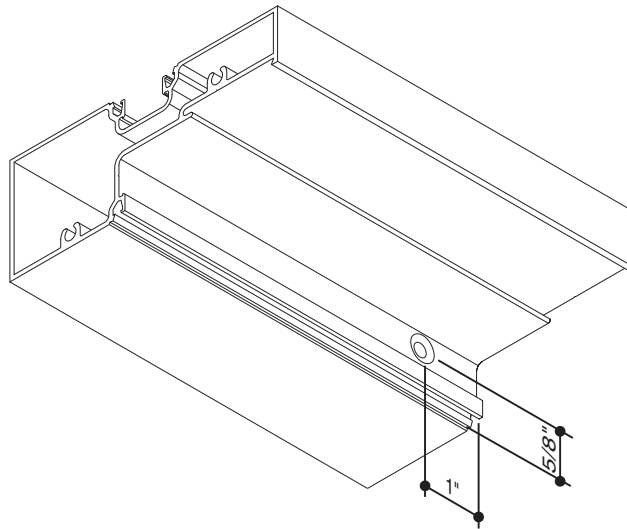

SILL

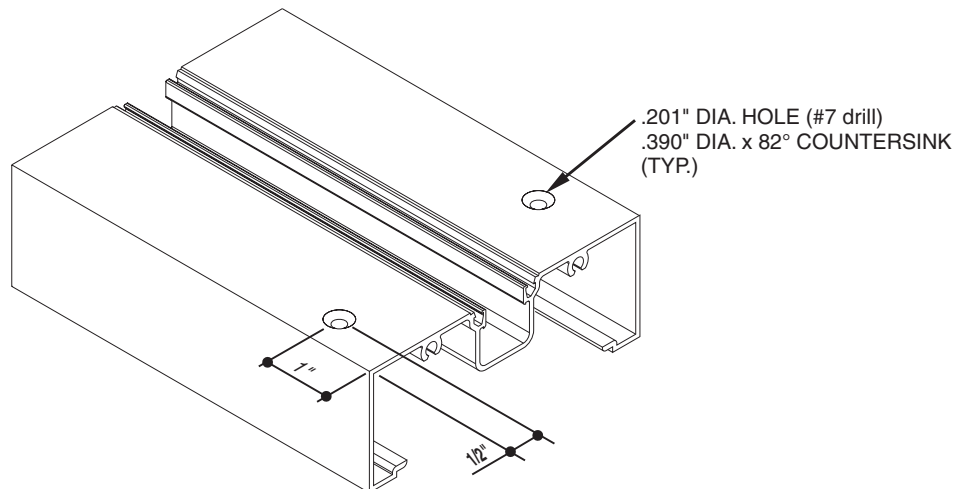

SECTION IV - DOOR JAMB SIDELITE FABRICATION & ASSEMBLY

SHEAR BLOCK PREPS FOR FRONT OR BACK OPTIONS

Step C: Cut horizontals to length = Daylight Opening, (Glass Stops should be D.L.O. - 1/16").

Step D: Fabricate head and sill by drilling and countersinking for #10 F.H. screws.

**FRONT - INSIDE GLAZED
OR
BACK - OUTSIDE GLAZED**

**FRONT - OUTSIDE GLAZED
OR
BACK - INSIDE GLAZED**

HEAD

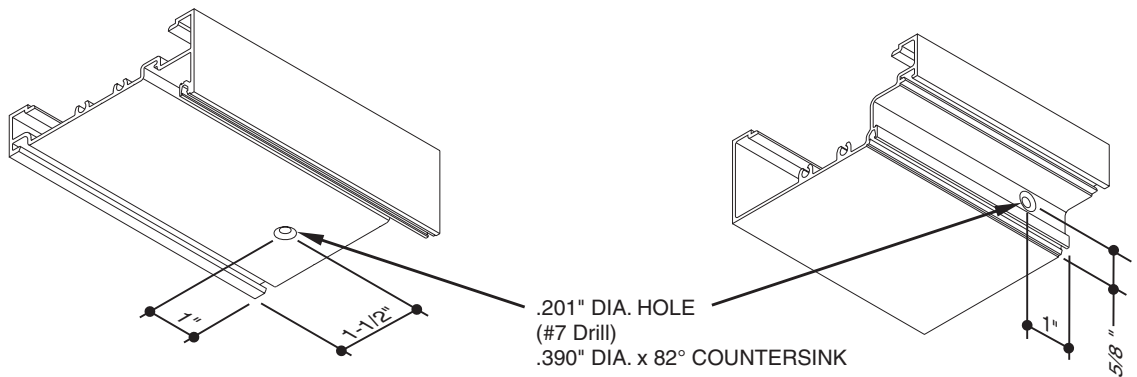

SILL

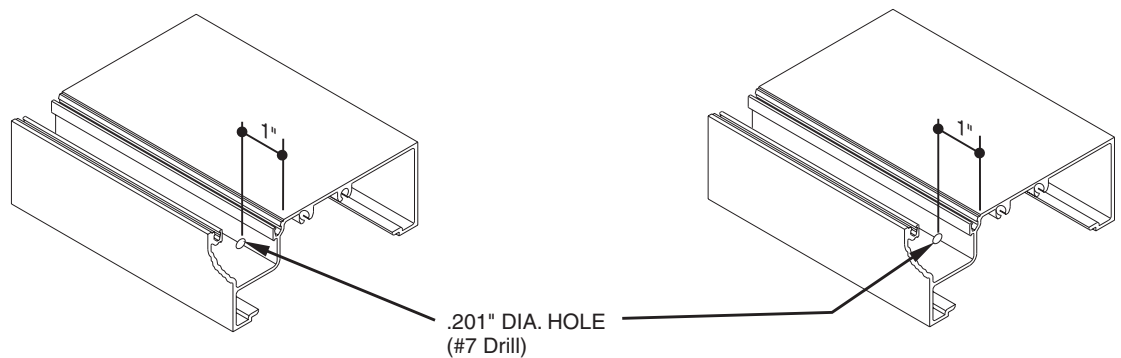

SECTION IV - DOOR JAMB SIDELITE FABRICATION & ASSEMBLY

STEP A: FOR CENTER OPTION INTERMEDIATE HORIZONTALS

Hold fabricated horizontal member in place over shear block and tight against vertical member. Then match drill tap hole in shear block with #26 drill (.147") slightly offset to **Vertical Mullion Side** of countersunk hole in the horizontal so as to pull the joint tight when assembled as shown below. (See Figure 1)

NOTE: FOR FRONT OR BACK INTERMEDIATE HORIZONTALS

Hold fabricated horizontal member in place over shear block and tight against vertical member. Then match drill tap hole in horizontal with #26 drill (.147") slightly offset to **D.L.O. Side** of hole in the shear block so as to pull the joint tight when assembled as shown below. (See Figure 2)

STEP B:

Apply sealant to the ends of all horizontal members, shear blocks and into reglets as shown below.

STEP C:

Attach horizontal members to shear blocks with fasteners provided in shear block packages.

STEP D:

Continue procedure above until entire frame is assembled.

STEP E:

Install flat fillers into head, jamb and sill at perimeter anchor locations.

Crimp material to prevent filler plate from sliding. Perimeter anchors should be located within 6" on each side of vertical mullions and 24" O.C. between vertical mullions.

NOTE:

IT IS IMPORTANT THAT THE INSTALLER APPLY SEALANT TO SHEAR BLOCKS, ENDS OF ALL HORIZONTAL MEMBERS AND GLAZING REGLETS AS SHOWN TO ENSURE GOOD SEAL.

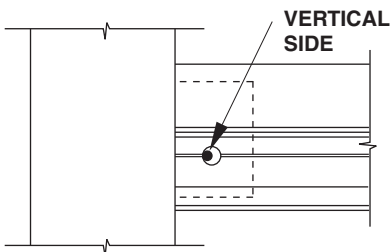

FIGURE 1
FOR CENTER OPTION
INTERMEDIATE HORIZONTALS

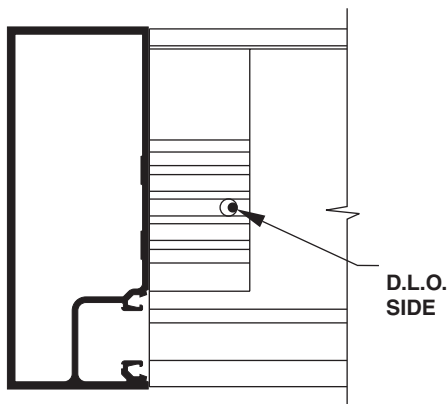
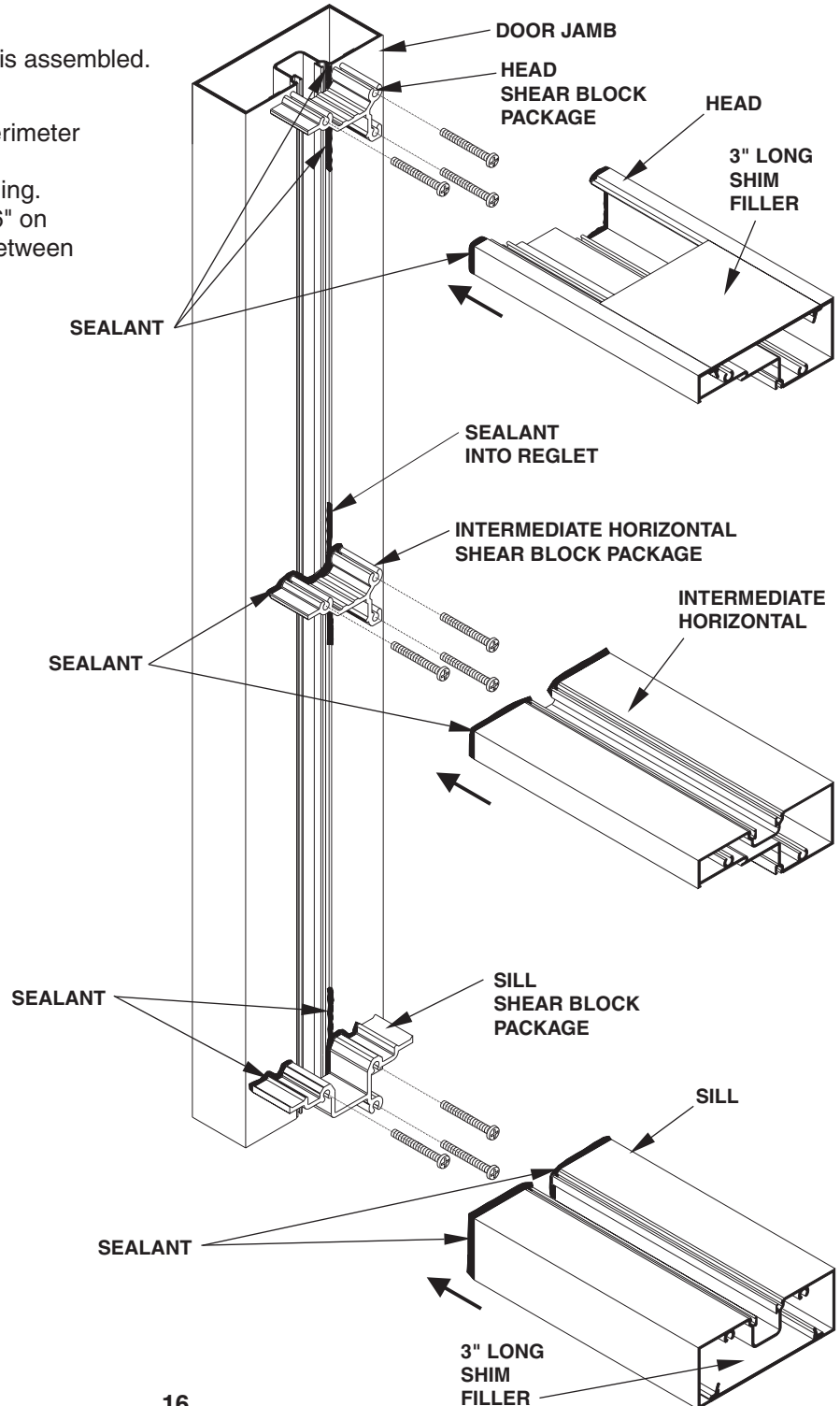

FIGURE 2
FOR FRONT OR BACK OPTION
INTERMEDIATE HORIZONTALS



SECTION V - FRAME FABRICATION & ASSEMBLY

SHEAR BLOCK PREPS FOR CENTER OPTION

Step A: Measure the opening to determine length of vertical and horizontal framing members. For all units that require sill flashing, allow a minimum of **1/8"** for standard flashing, **3/8"** for thermal flashing and **7/16"** for high-performance flashing when measuring vertical lengths. Allow 1/4" min. clearance at the head, sill, and each jamb to facilitate installation and provide space for caulking. If job conditions are uncertain, or masonry openings are irregular, or if high-performance flashing is used, allow extra clearance to accommodate construction tolerance.

Step B: Cut vertical members to required length (Frame Height). At desired horizontal locations drill the proper holes in the verticals for attachment of the shear blocks, as shown below.

Step C: Attach shear blocks to vertical mullions using #28-400 (#10 x 1-19/32" P.H.) screws as required.

TRIFAB VG 451 (CENTER OPTION)

PLACE JIG ONTO MULLION AS SHOWN BELOW

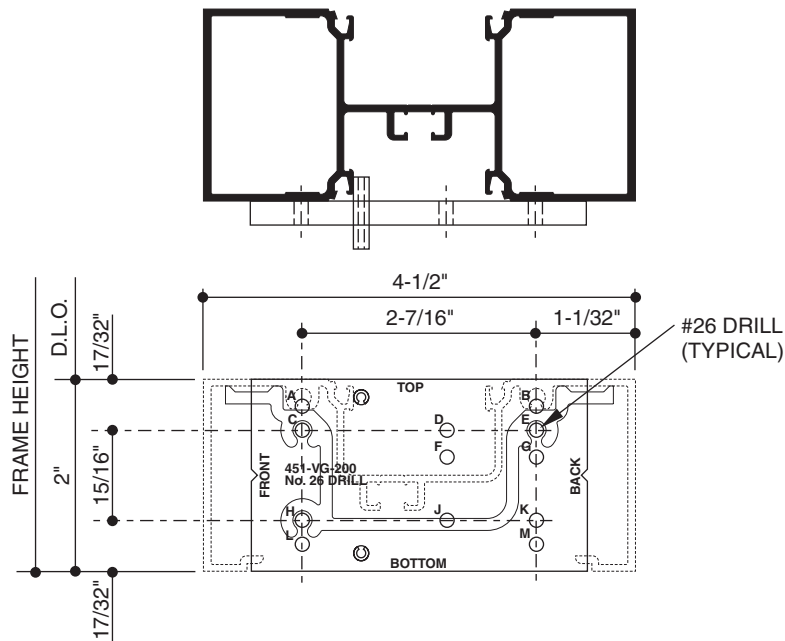

OUTSIDE GLAZED (STOPS DOWN)



HEAD PREP = HOLES (E, K)



HORIZONTAL PREP = HOLES (E, K)

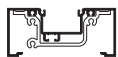

SILL PREP = HOLES (C, E, H)

OUTSIDE GLAZED (STOPS DOWN) WITH OPTIONAL HORIZONTAL



HEAD PREP = HOLES (E, K)



HORIZONTAL PREP = HOLES (A, B, K)

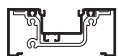

SILL PREP = HOLES (C, E, H)

OUTSIDE GLAZED (STOPS UP)



HEAD PREP = HOLES (C, H, K)



HORIZONTAL PREP = HOLES (E, K)



SILL PREP = HOLES (E, K)

OUTSIDE GLAZED (STOPS UP) WITH OPTIONAL HORIZONTAL



HEAD PREP = HOLES (C, H, K)



HORIZONTAL PREP = HOLES (E, L, M)



SILL PREP = HOLES (E, K)

SECTION V - FRAME FABRICATION & ASSEMBLY

SHEAR BLOCK PREPS FOR CENTER OPTION

Step A: Measure the opening to determine length of vertical and horizontal framing members. For all units that require sill flashing, allow a minimum of **1/8"** for standard flashing, **3/8"** for thermal flashing and **7/16"** for high-performance flashing when measuring vertical lengths. Allow 1/4" min. clearance at the head, sill, and each jamb to facilitate installation and provide space for caulking. If job conditions are uncertain, or masonry openings are irregular, or if high-performance flashing is used, allow extra clearance to accommodate construction tolerance.

Step B: Cut vertical members to required length (Frame Height). At desired horizontal locations drill the proper holes in the verticals for attachment of the shear blocks, as shown below.

Step C: Attach shear blocks to vertical mullions using #28-400 (#10 x 1-19/32" P.H.) screws as required.

TRIFAB VG 451 (CENTER OPTION)

PLACE JIG ONTO MULLION AS SHOWN BELOW

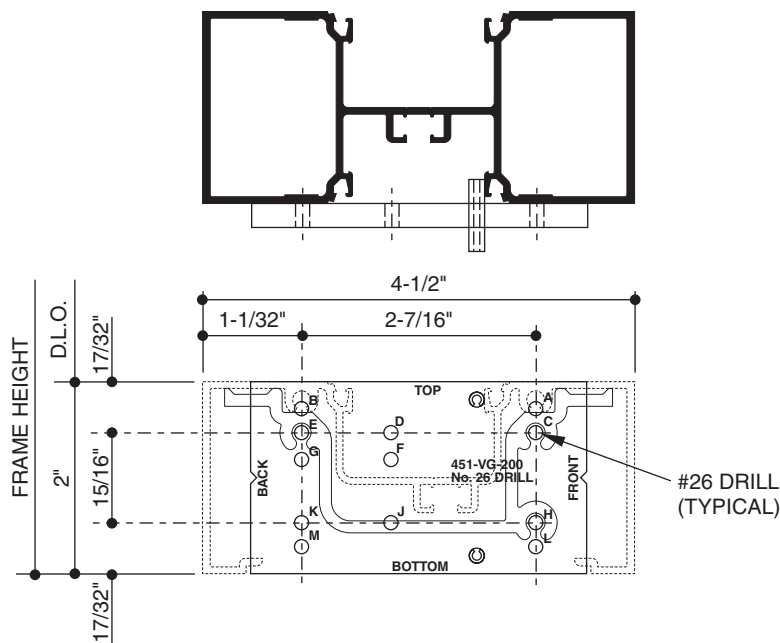

INSIDE GLAZED



HEAD PREP = HOLES (E, K)



HORIZONTAL PREP = HOLES (E, K)



SILL PREP = HOLES (C, E, H)

INSIDE GLAZED WITH OPTIONAL HORIZONTAL



HEAD PREP = HOLES (C, H)

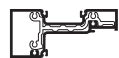

HORIZONTAL PREP = HOLES (A, B, K)

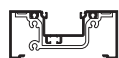

SILL PREP = HOLES (C, E, H)

SECTION V - FRAME FABRICATION & ASSEMBLY

SHEAR BLOCK PREPS FOR CENTER OPTION

Step D: Cut horizontals to length = Daylight Opening. (Glass stops should be D.L.O. - 1/16").

Step E: Fabricate head, sill, and intermediate horizontals by drilling and countersinking for #10 F.H. screws as shown.

HEAD

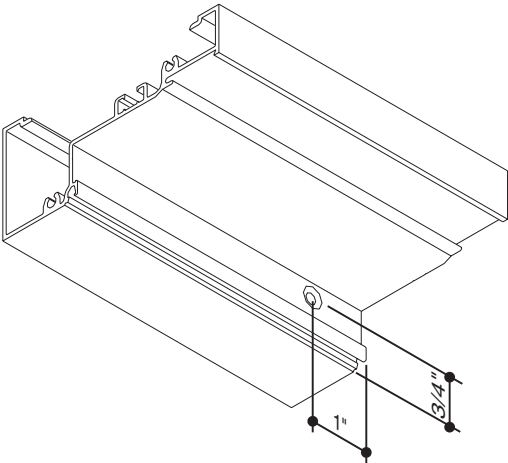

HORIZONTAL

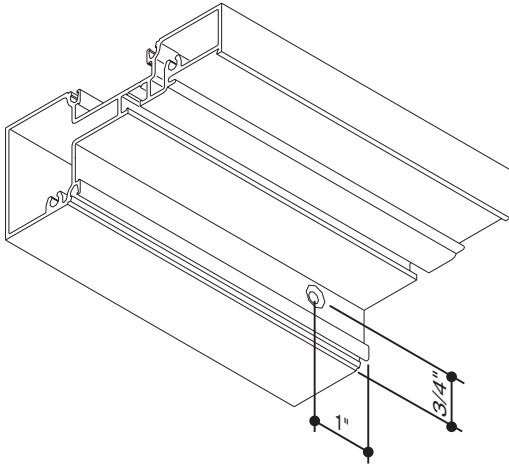

SILL

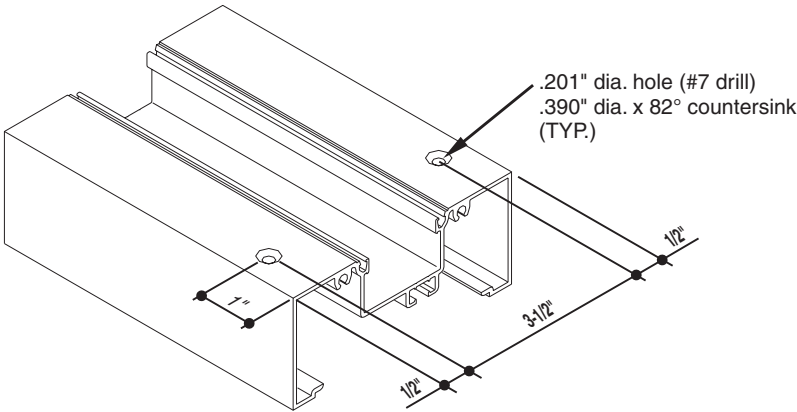

SECTION V - FRAME FABRICATION & ASSEMBLY

SHEAR BLOCK PREPS FOR FRONT or BACK OPTION

Step A: Measure the opening to determine length of vertical and horizontal framing members. For all units that require sill flashing, allow a minimum of **1/8"** for standard flashing and **7/16"** for high-performance flashing when measuring vertical lengths. Allow 1/4" min. clearance at the head, sill, and each jamb to facilitate installation and provide space for caulking. If job conditions are uncertain, or masonry openings are irregular, or if high-performance flashing is used, allow extra clearance to accommodate construction tolerance.

Step B: Cut vertical members to required length (Frame Height). At desired horizontal locations drill the proper holes in the verticals for attachment of the shear blocks, as shown below.

Step C: Attach shear blocks to vertical mullions using #28-400 (#10 x 1-19/32" P.H.) screws as required.

TRIFAB VG 451 (FRONT OPTION)

PLACE JIG ONTO MULLION AS SHOWN BELOW

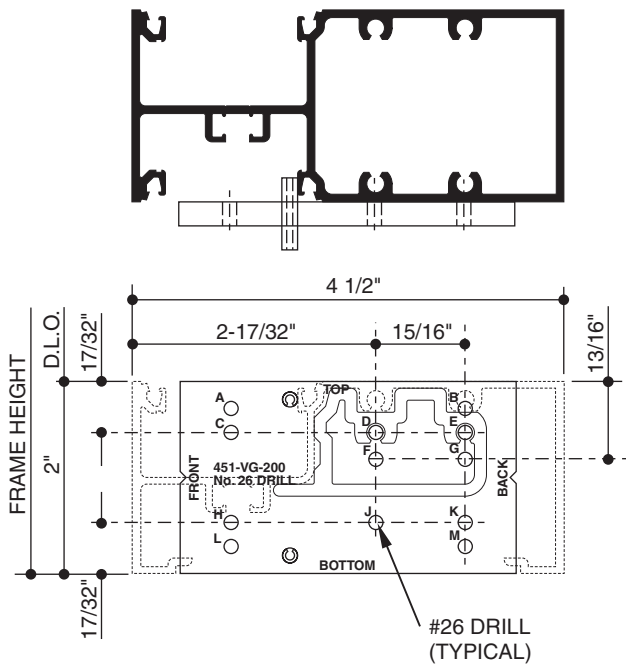

TRIFAB VG 451 (BACK OPTION)

PLACE JIG ONTO MULLION AS SHOWN BELOW

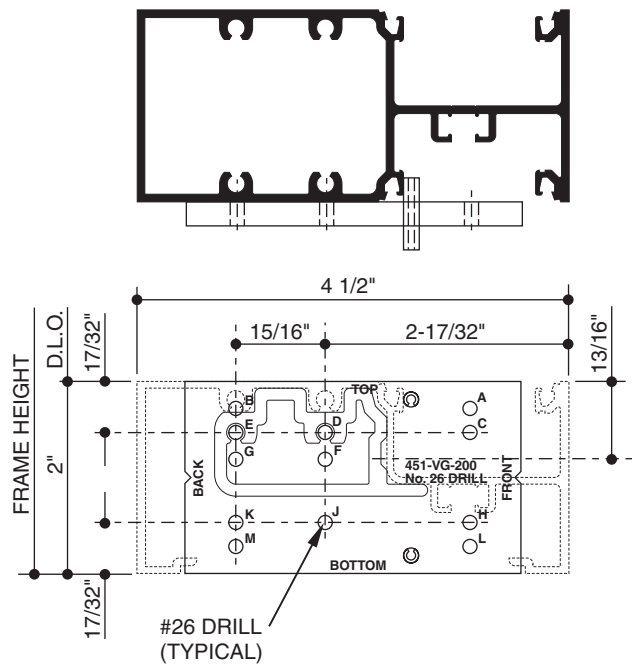

OUTSIDE GLAZED



HEAD PREP = HOLES (J, K)



HORIZONTAL PREP = HOLES (F, G)



SILL PREP = HOLES (D, E)

OUTSIDE GLAZED



HEAD PREP = HOLES (D, E)



HORIZONTAL PREP = HOLES (F, G)

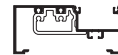

SILL PREP = HOLES (D, E)

INSIDE GLAZED



HEAD PREP = HOLES (D, E)



HORIZONTAL PREP = HOLES (F, G)

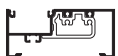

SILL PREP = HOLES (D, E)

INSIDE GLAZED



HEAD PREP = HOLES (J, K)



HORIZONTAL PREP = HOLES (F, G)

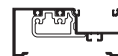

SILL PREP = HOLES (D, E)

SECTION V - FRAME FABRICATION & ASSEMBLY

SHEAR BLOCK PREPS FOR FRONT OR BACK OPTION

Step D: Cut horizontals to length = Daylight Opening. (Glass stops should be D.L.O. - 1/16").

Step E: Fabricate head and sill by drilling and countersinking for #10 F.H. screws as shown.

**FRONT - INSIDE GLAZED
OR
BACK - OUTSIDE GLAZED**

**FRONT- OUTSIDE GLAZED
OR
BACK - INSIDE GLAZED**

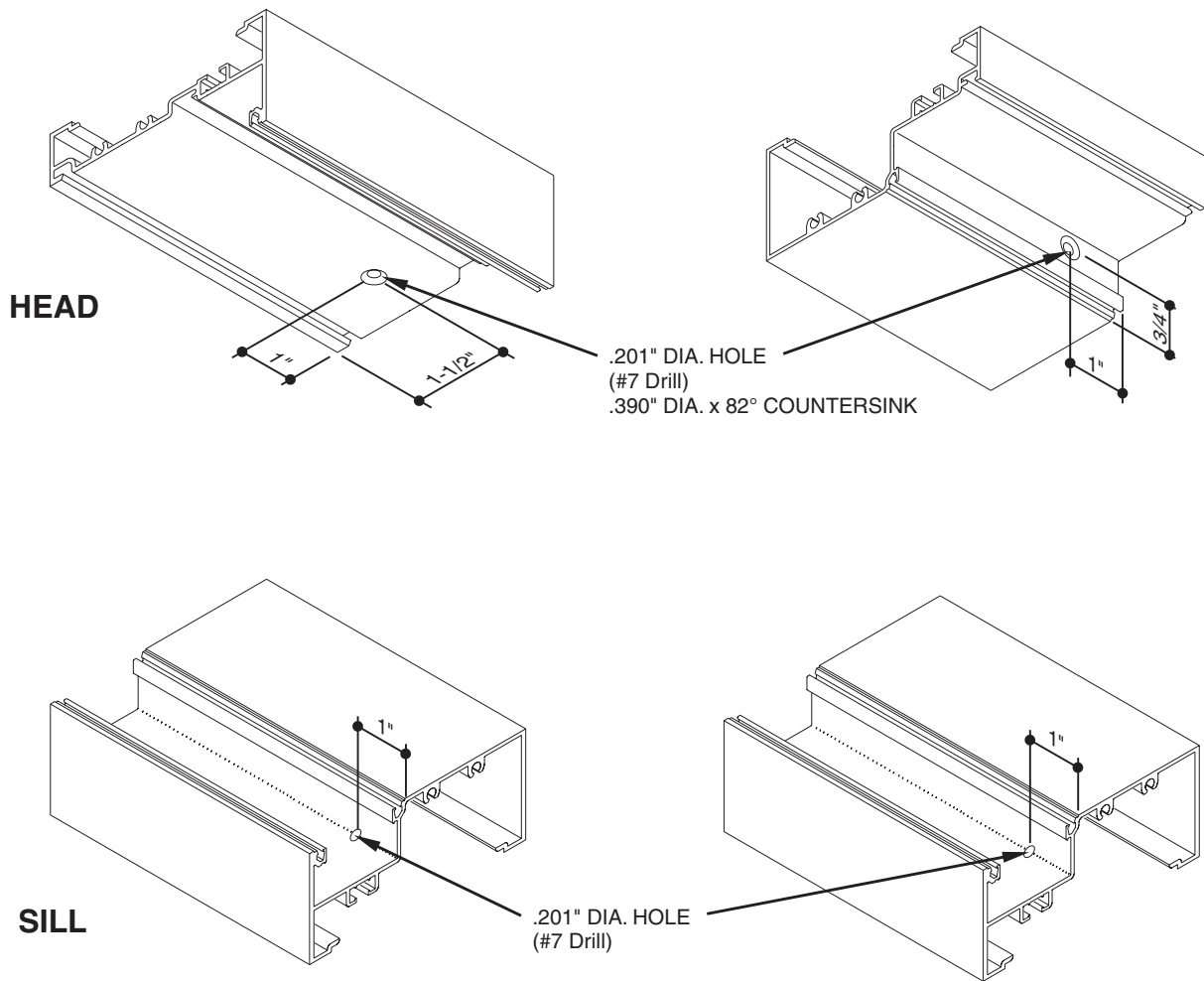

SECTION V - FRAME FABRICATION & ASSEMBLY

STEP A:

Hold fabricated horizontal member in place over shear block and tight against vertical member. Then match drill tap hole in shear block with #26 drill (.147") slightly offset to **Vertical Mullion Side** of countersink hole in the horizontal so as to pull the joint tight when assembled as shown below (See Figure 1).

NOTE: FOR FRONT OR BACK OPTION INTERMEDIATE HORIZONTALS

Hold fabricated horizontal member in place over shear block and tight against vertical member. Then match drill tap hole in horizontal with #26 drill (.147") slightly offset to **D.L.O. Side** of hole in the shear block so as to pull the joint tight when assembled as shown below (See Figure 2).

STEP B:

Apply sealant to the ends of all horizontal members, shear blocks and into reglets as shown below.

STEP C:

Attach horizontal members to shear blocks with fasteners provided in shear block packages.

STEP D:

Continue procedure above until entire frame is assembled.

STEP E:

Install flat fillers into head, jamb and sill at perimeter anchor locations.

Crimp material to prevent filler plate from sliding. Perimeter anchors should be located within 6" on each side of vertical mullions and 24" O.C. between vertical mullions.

NOTE:

IT IS IMPORTANT THAT THE INSTALLER APPLY SEALANT TO SHEAR BLOCKS, ENDS OF ALL HORIZONTAL MEMBERS AND GLAZING REGLETS AS SHOWN TO ENSURE GOOD SEAL. GLAZING ADAPTERS MUST ALSO BE SEALED AT THE HORIZONTAL TO VERTICAL JOINT. (SEE SECTION VIII FOR ADDITIONAL INFORMATION.)

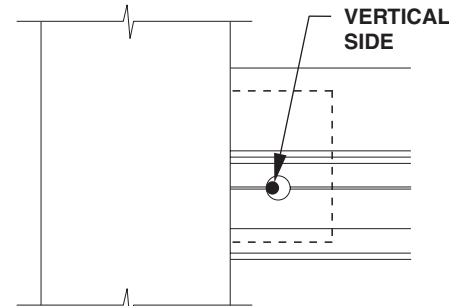

FIGURE 1
FOR CENTER OPTION
INTERMEDIATE HORIZONTALS

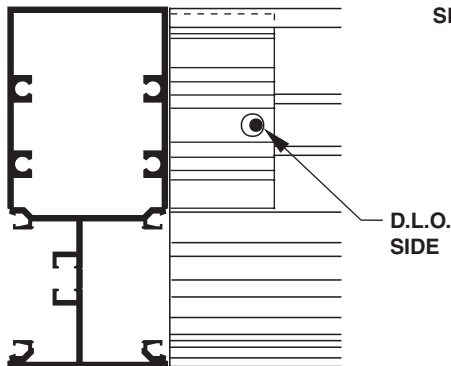
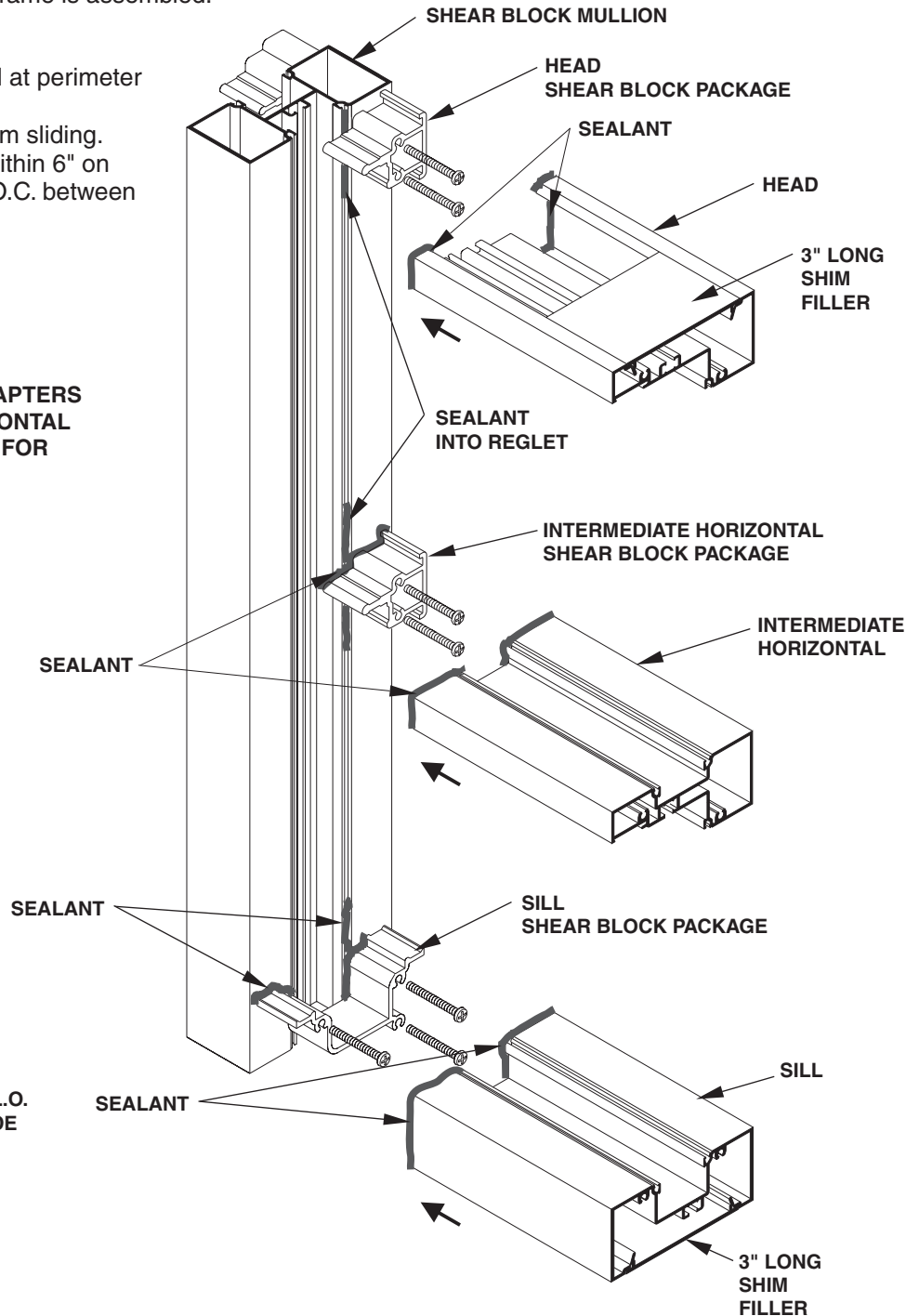

FIGURE 2
FOR FRONT OR BACK OPTION
INTERMEDIATE HORIZONTALS



SECTION VI - DOOR JAMB SIDELITE FABRICATION & ASSEMBLY SHEAR BLOCK PREPS

Apply the same shear block preps on Door Jambs that were applied to vertical mullions, allowing for shim space and sill flashing at sill, as shown below.

Step A: At desired horizontal locations drill the proper holes in the door jambs for attachment of the shear blocks, as shown below.

Step B: Attach shear blocks to door jambs using #28-400 (#10 x 1-19/32" P.H.) screws as required.

TRIFAB VG 451 (FRONT OPTION)

PLACE JIG ONTO MULLION AS SHOWN BELOW

TRIFAB VG 451 (BACK OPTION)

PLACE JIG ONTO MULLION AS SHOWN BELOW

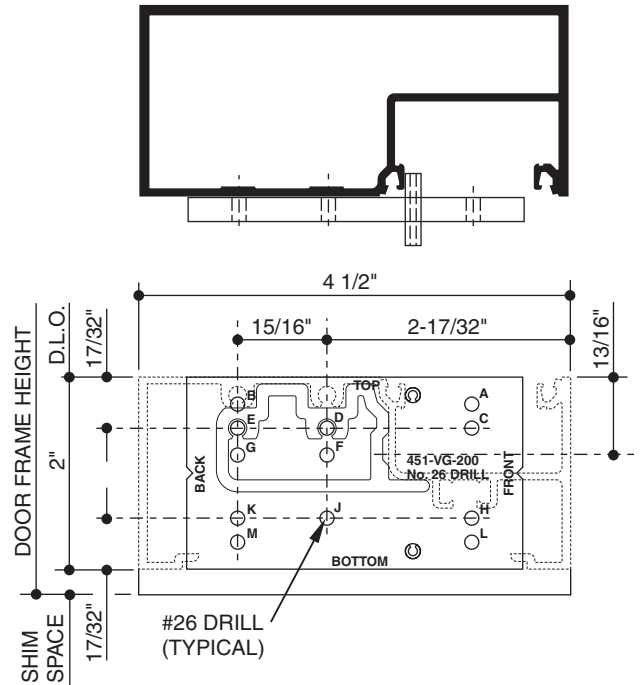
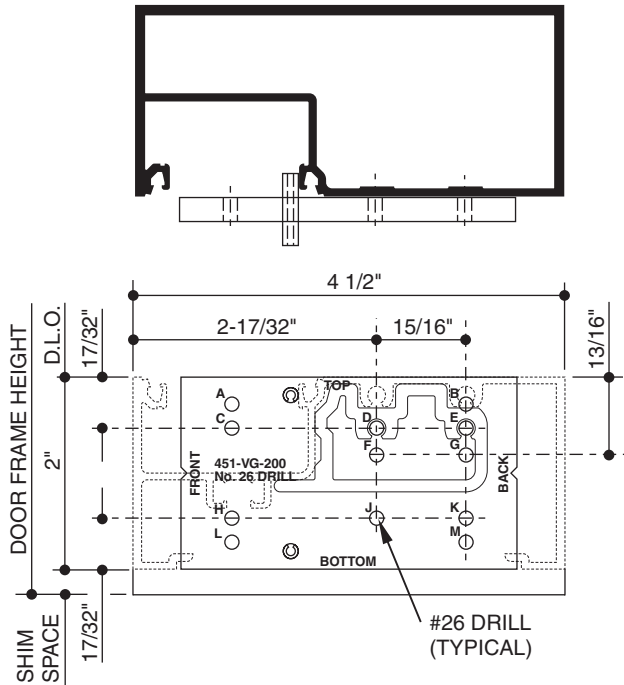

TRIFAB VG 451 (CENTER OPTION)

PLACE JIG ONTO MULLION AS SHOWN BELOW

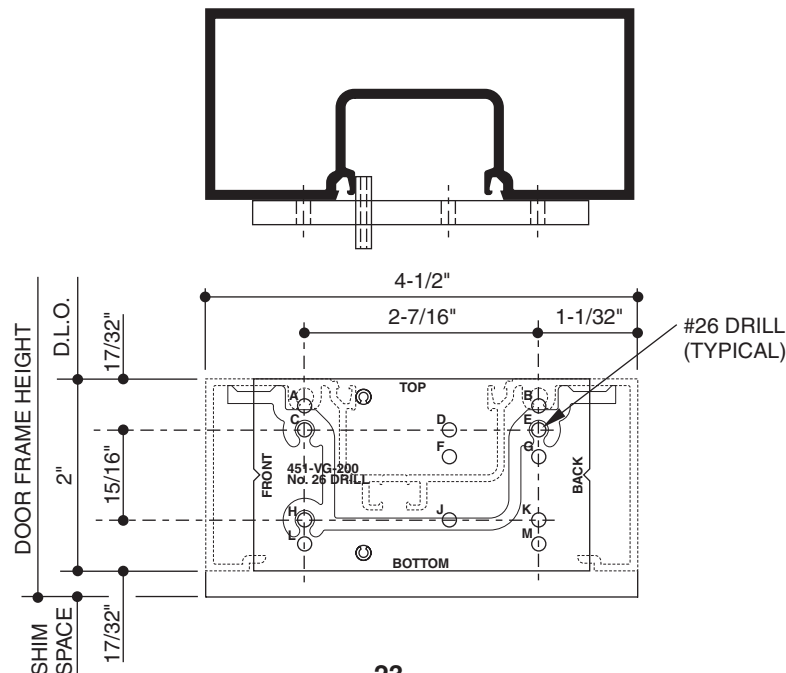

SECTION VI - DOOR JAMB SIDELITE FABRICATION & ASSEMBLY

SHEAR BLOCK PREPS FOR CENTER OPTION

Step C: Cut horizontals to length = Daylight Opening, (Glass stops should be D.L.O. - 1/16").

Step D: Fabricate head, sill, and intermediate horizontals by drilling and countersinking for #10 F.H. screws.

HEAD

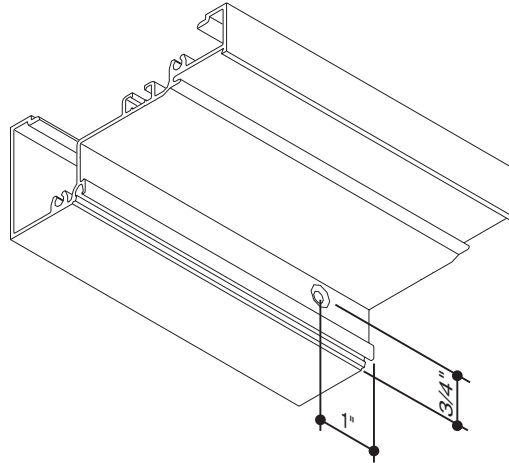

HORIZONTAL

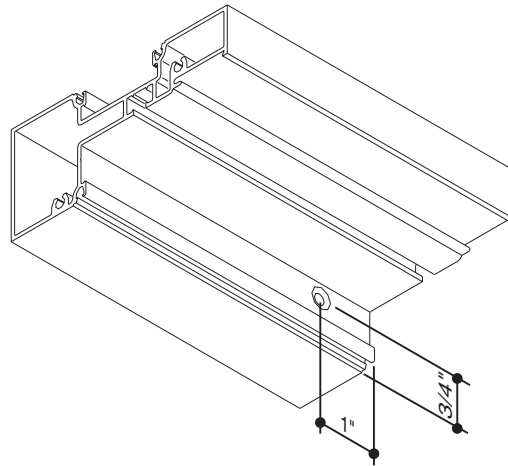

SILL

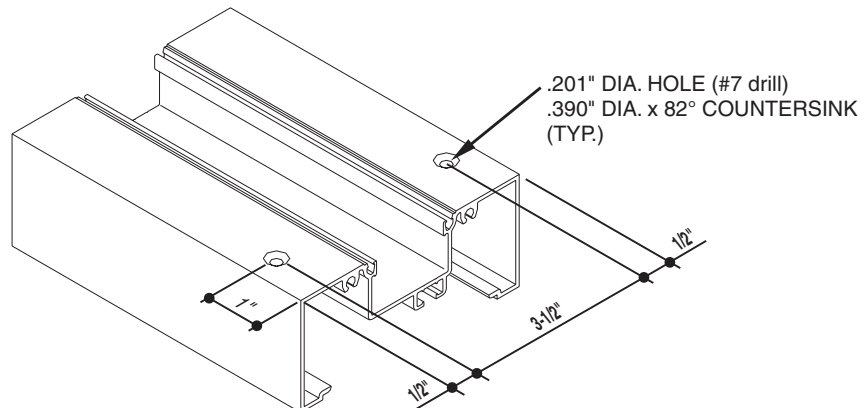

SECTION VI - DOOR JAMB SIDELITE FABRICATION & ASSEMBLY

SHEAR BLOCK PREPS FOR FRONT OR BACK OPTIONS

Step C: Cut horizontals to length = Daylight Opening, (Glass Stops should be D.L.O. - 1/16").

Step D: Fabricate head and sill by drilling and countersinking for #10 F.H. screws.

**FRONT - INSIDE GLAZED
OR
BACK - OUTSIDE GLAZED**

**FRONT - OUTSIDE GLAZED
OR
BACK - INSIDE GLAZED**

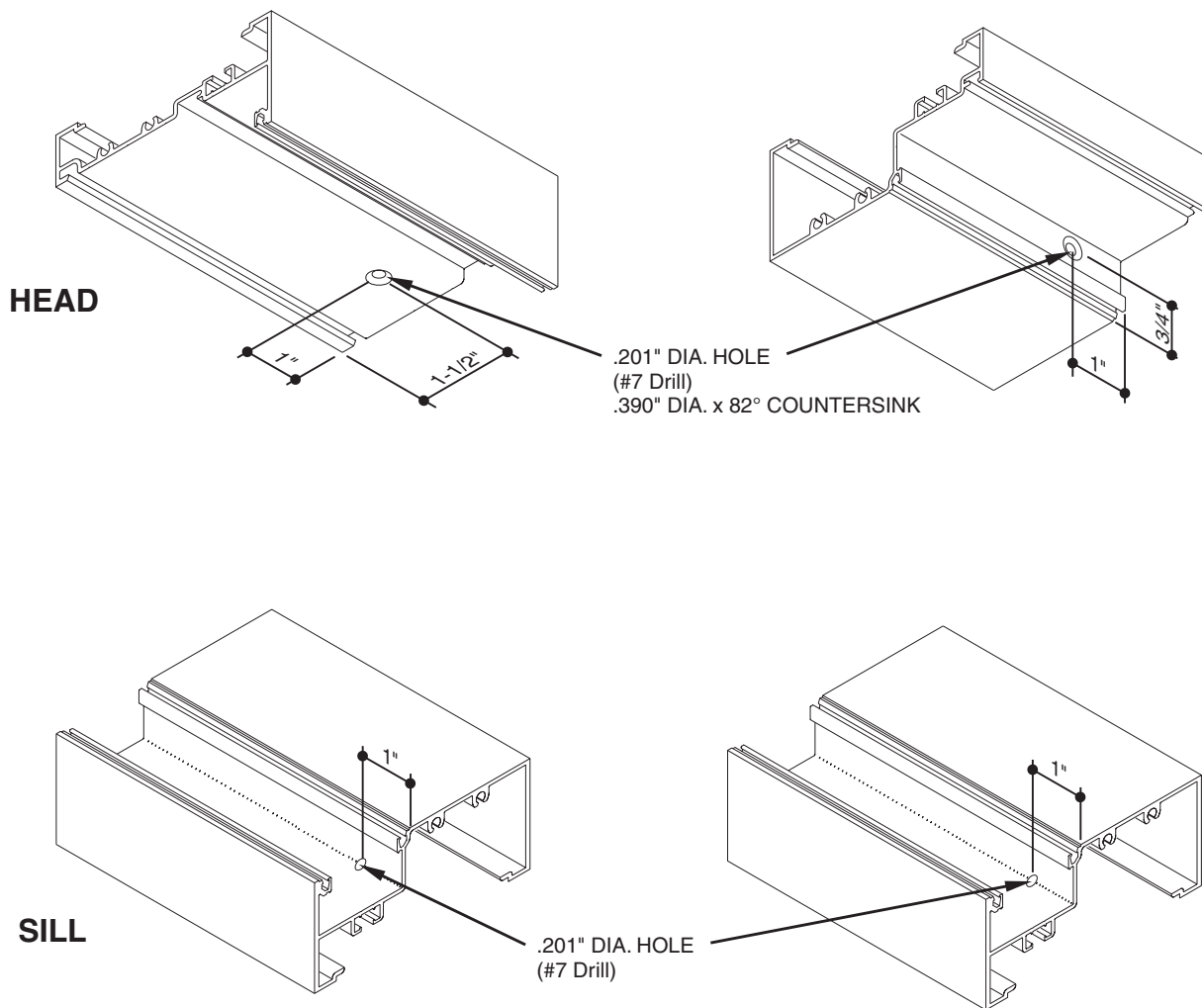

SECTION VI - DOOR JAMB SIDELITE FABRICATION & ASSEMBLY

STEP A: FOR CENTER OPTION INTERMEDIATE HORIZONTALS

Hold fabricated horizontal member in place over shear block and tight against vertical member. Then match drill tap hole in shear block with #26 drill (.147") slightly offset to **Vertical Mullion Side** of countersunk hole in the horizontal so as to pull the joint tight when assembled as shown below. (See Figure 1)

NOTE: FOR FRONT OR BACK INTERMEDIATE HORIZONTALS

Hold fabricated horizontal member in place over shear block and tight against vertical member. Then match drill tap hole in horizontal with #26 drill (.147") slightly offset to **D.L.O. Side** of hole in the shear block so as to pull the joint tight when assembled as shown below. (See Figure 2)

STEP B:

Apply sealant to the ends of all horizontal members, shear blocks and into reglets as shown below.

STEP C:

Attach horizontal members to shear blocks with fasteners provided in shear block packages.

STEP D:

Continue procedure above until entire frame is assembled.

STEP E:

Install flat fillers into head, jamb and sill at perimeter anchor locations.

Crimp material to prevent filler plate from sliding. Perimeter anchors should be located within 6" on each side of vertical mullions and 24" O.C. between vertical mullions.

NOTE:

IT IS IMPORTANT THAT THE INSTALLER APPLY SEALANT TO SHEAR BLOCKS, ENDS OF ALL HORIZONTAL MEMBERS AND GLAZING REGLETS AS SHOWN TO ENSURE GOOD SEAL. GLAZING ADAPTERS MUST ALSO BE SEALED AT THE HORIZONTAL TO VERTICAL JOINT. (SEE SECTION VIII FOR ADDITIONAL INFORMATION.)

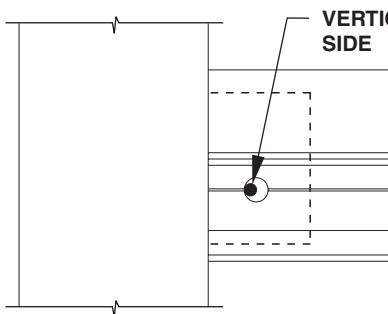

FIGURE 1
FOR CENTER OPTION
INTERMEDIATE HORIZONTALS

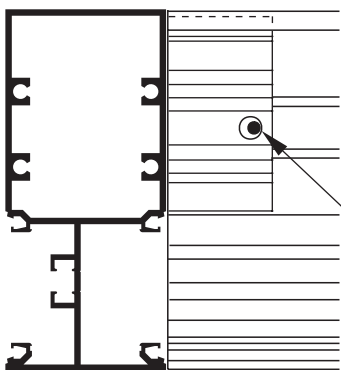
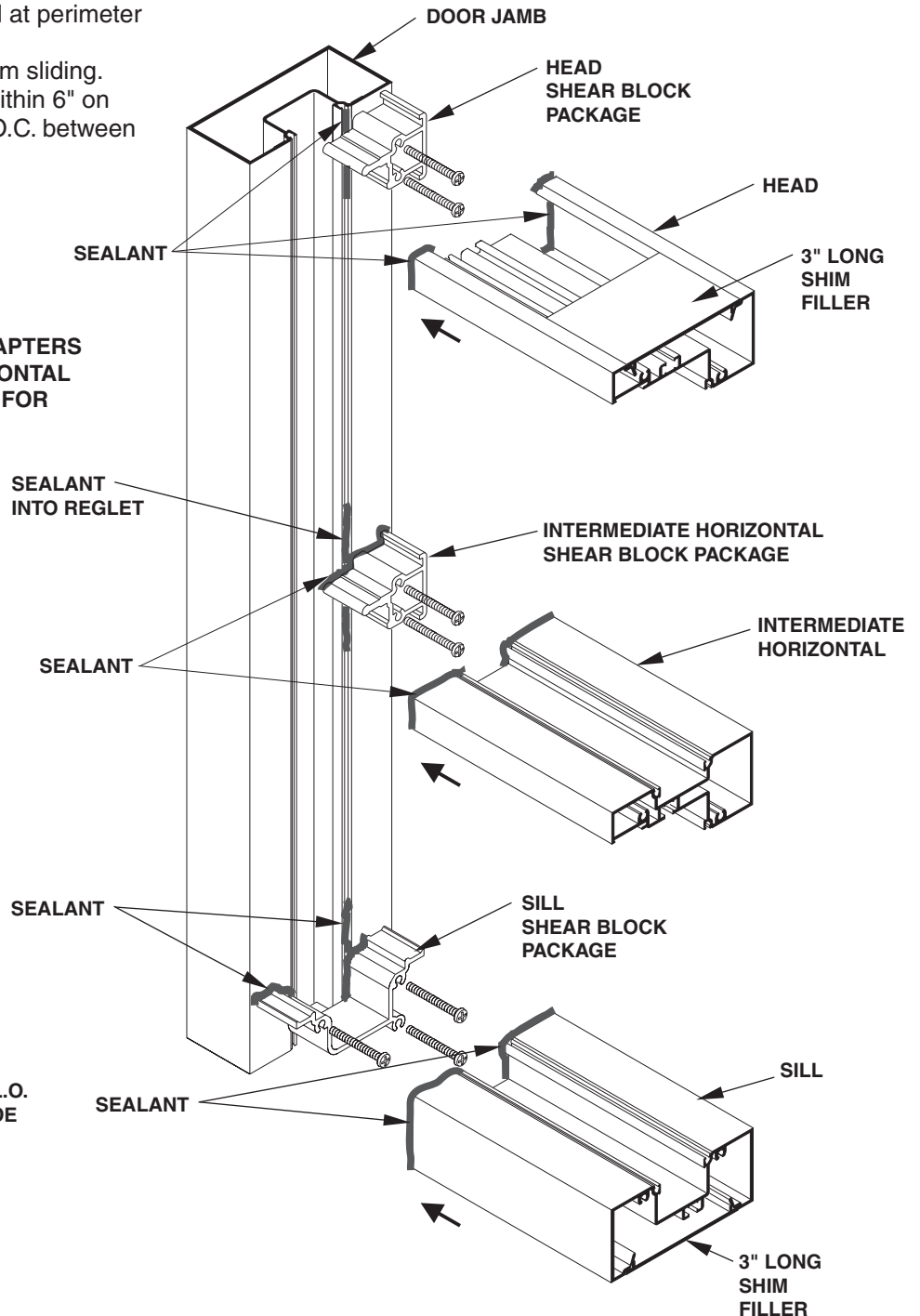

FIGURE 2
FOR FRONT OR BACK OPTION
INTERMEDIATE HORIZONTALS



SECTION VII - INSTALLATION

SILL FLASHING, SPLICES AND END DAMS

SILL FLASHING

1. Measure rough opening to determine frame size and flashing length. Allow minimum of 1/4" clearance at head and jambs for frame clearance. Flashing will run the full width of the opening minus (-)1/4". If opening is over 24'-0" wide a splice joint required every 12'-0". (See splice joint procedure)
2. Install flashing at the sill. It should be level, shimmed up a minimum of 1/4", and carefully sealed at both end dams as shown on Page 28. Seal over the heads of all perimeter fasteners.

HP SILL FLASHING

1. Measure rough opening to determine frame size and HP flashing length. Allow minimum of 3/8" clearance at head and jambs for frame clearance. HP flashing will run the full width of opening minus (-)1/4". If opening is over 24'-0" wide a splice joint is required every 12'-0". (See splice joint procedure)
2. Drill 1/4" diameter weep holes at 1/4 points of lite opening. (Figure 1)
3. Install flashing at the sill. It should be level, shimmed up a minimum of 1/4" and carefully sealed at both end dams as shown on Page 28. Seal over the heads of all perimeter fasteners.

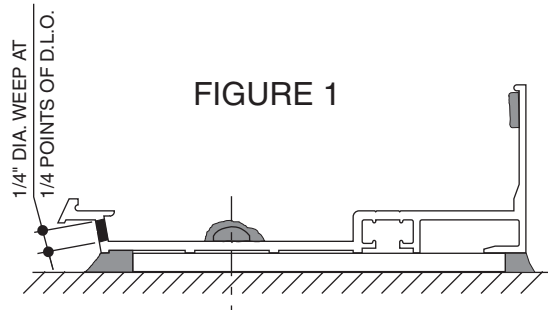

SPLICE JOINTS

SPLICES SHOULD BE LOCATED A MAXIMUM OF EVERY 12'-0" WITH A 1/2" JOINT BETWEEN HEAD & SILL MEMBERS. DO NOT LOCATE SPLICE DIRECTLY UNDER A VERTICAL MULLION.

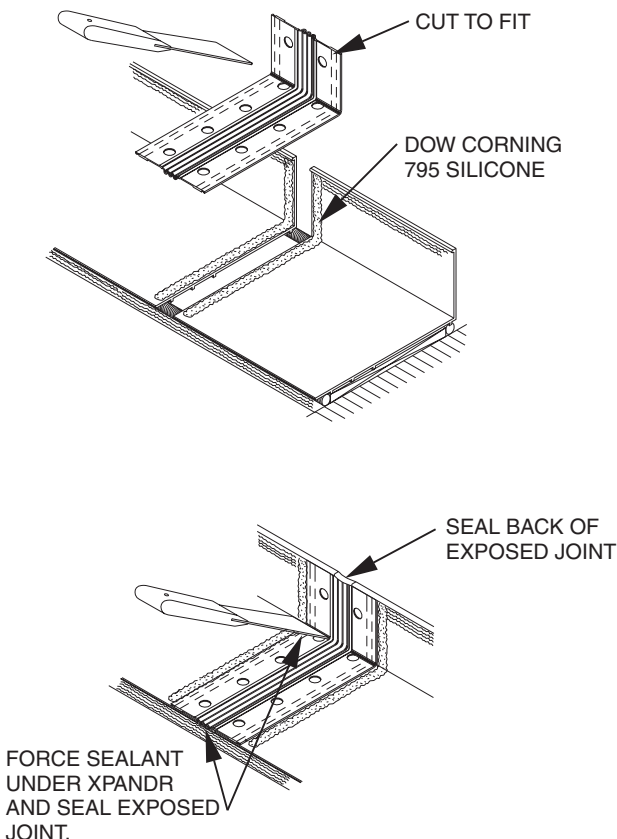

PROCEDURE FOR INSTALLING KAWNEER XPANDR™ SPLICE SLEEVE

1. Cut XPANDR Splice Sleeve (27-094) to length and form using a putty knife to bend the material square.
2. Clean splice area with solvent.
3. Apply bead of DOW 795 silicone within 1/4" of the edge of the sill members on each side of the 1/2" joint.
4. Remove protective liner from adhesive tape. (For cold weather applications see Note below)
5. Center the XPANDR splice sleeve over joint. Then, using a putty knife, seat the XPANDR into corner and onto surface of sill member.
6. Sealant will squeeze out through holes. use putty knife to tool off excess silicone.
7. Seal back of exposed joint and apply perimeter seals. Be sure to force sealant up under the XPANDR Splice Sleeve in front.

COLD WEATHER NOTE:

For temperatures below 40° the following precautions should be taken. Just prior to installing XPANDR, wipe flashing material with a solvent or cleaning solution recommended by the sealant manufacturer. This will remove any condensation or frost that may be present.

CAUTION: Carefully follow the recommendations contained in the material safety data sheet provided by the solvent/cleaning solution manufacturer regarding health and fire/explosion risks.

NOTE:
Alternate silicones must be tested and approved by sealant manufacturer.

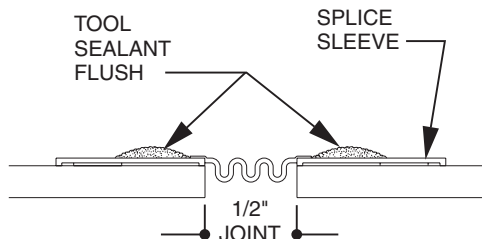

SECTION VII - INSTALLATION

SILL FLASHING, SPLICES AND END DAMS

END DAM

Pin End Dam to Flashing prior to installation.
Seal any fastener shanks that pierce flashing.

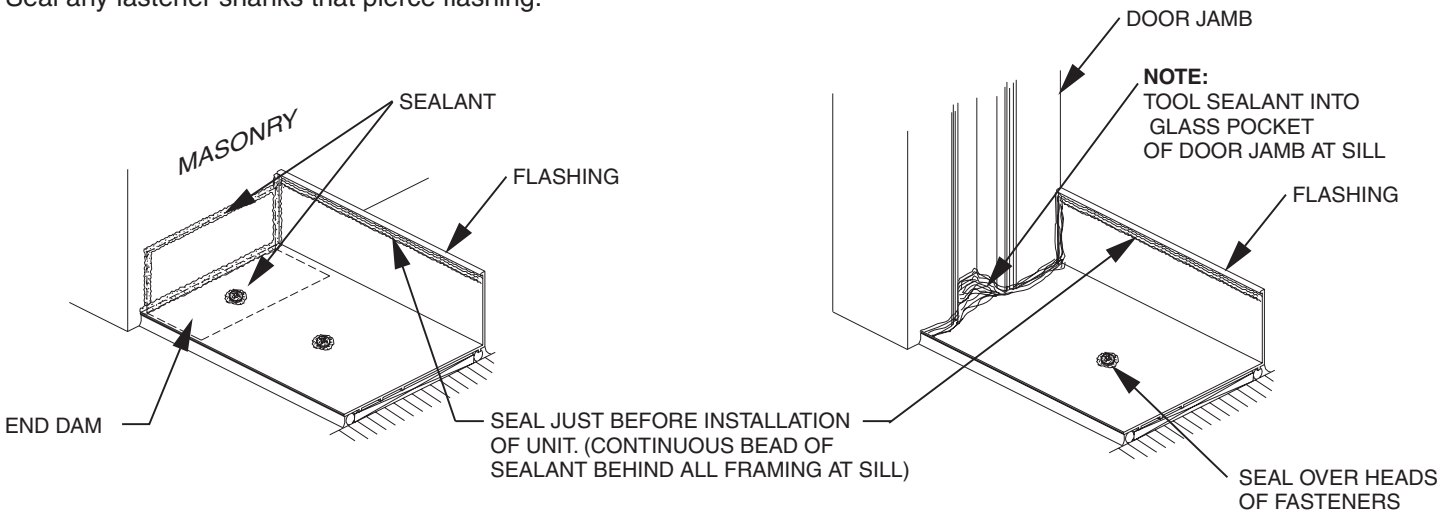

STEP A: Miter two 12" sections of sill flashing to correct angle.

STEP B: Set mitered joint in a bed of sealant and securely anchor corner into place with a tight joint.

STEP C: Completely seal non-moving mitered joint and anchors

STEP D: Use XPANDR™ splice sleeve at point 12" from corner.

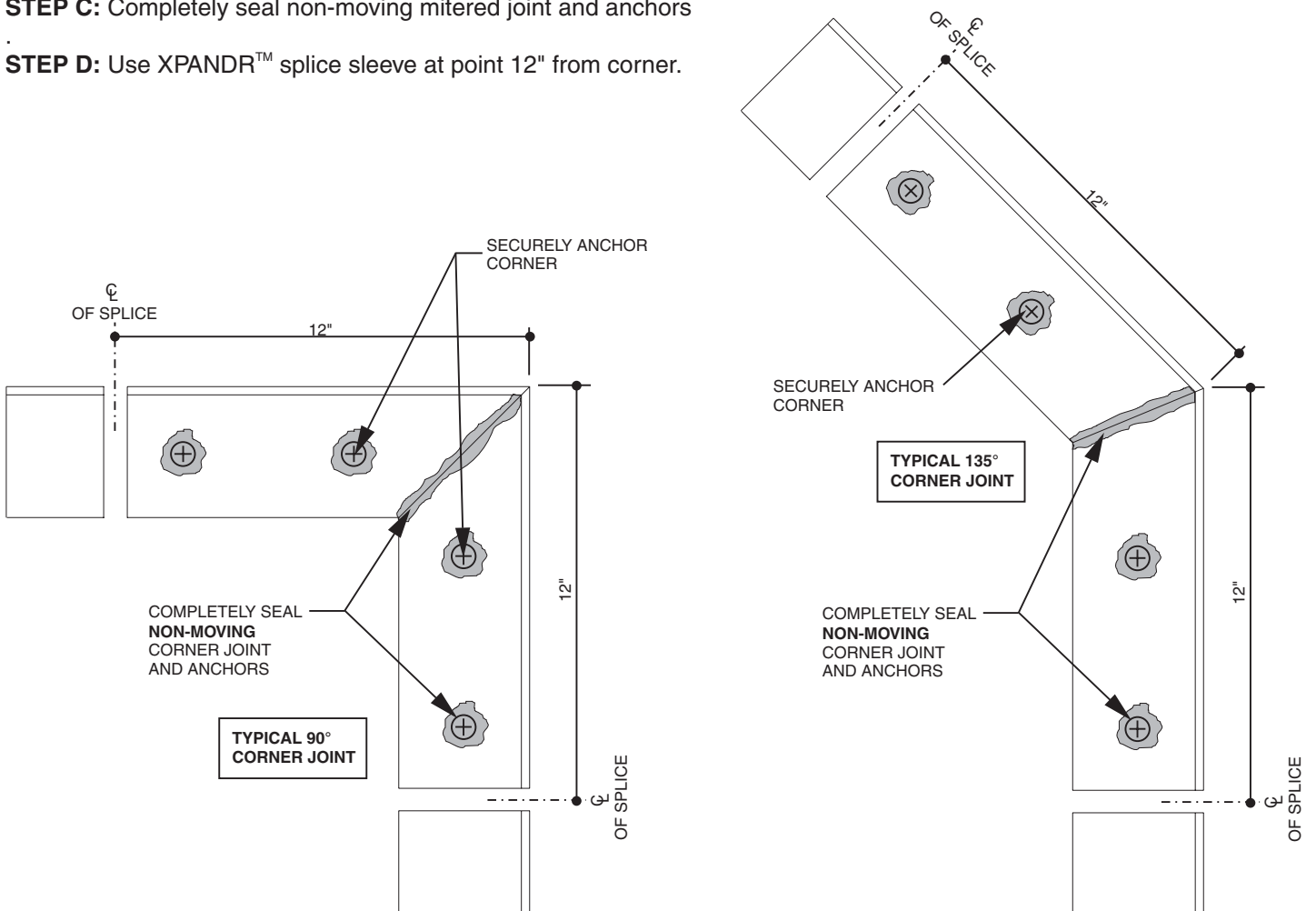

SECTION VII - INSTALLATION

HEAD RECEPTOR SPLICE JOINT

Install Splice Sleeve onto Head Receptor as shown.

NOTE:

Alternate silicones must be tested and approved by sealant manufacturer.

DOW CORNING 795 SILICONE

XPANDR™ SPLICE SLEEVE
CUT TO FIT

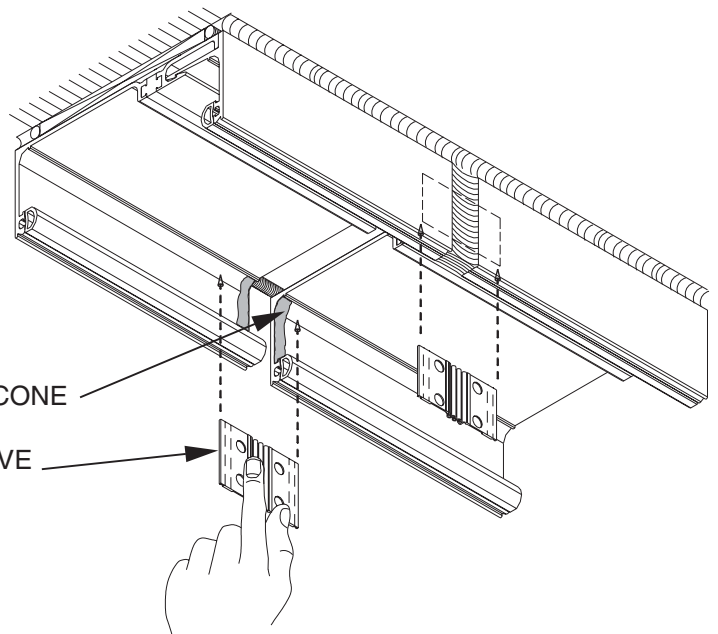

JAMB RECEPTOR AT SILL FLASHING

Seal jamb receptor at sill flashing as shown.

NOTE:

BACK SEAL THE EDGE OF THE RECEPTOR ALONG THE UPTURNED LEG OF THE FLASHING. TOOL SEALANT TO PROVIDE SEAL BETWEEN RECEPTOR, FLASHING AND RECEPTOR GASKET.

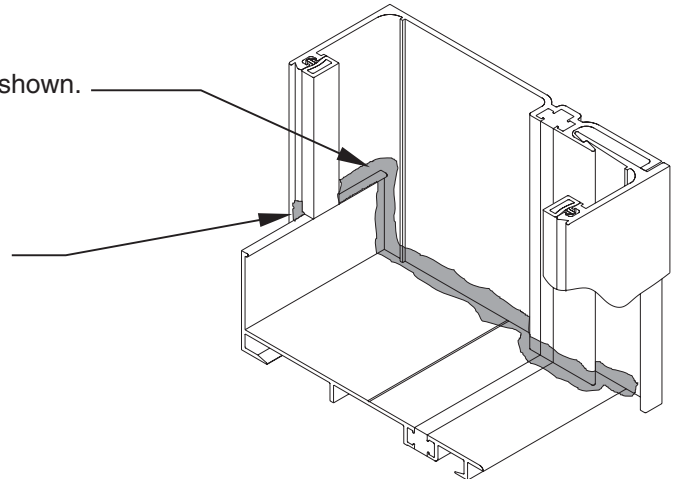

SHIM INSTALLATION

Install support shims at head, sill and jamb. Place between pocket filler and perimeter condition at perimeter anchor locations.

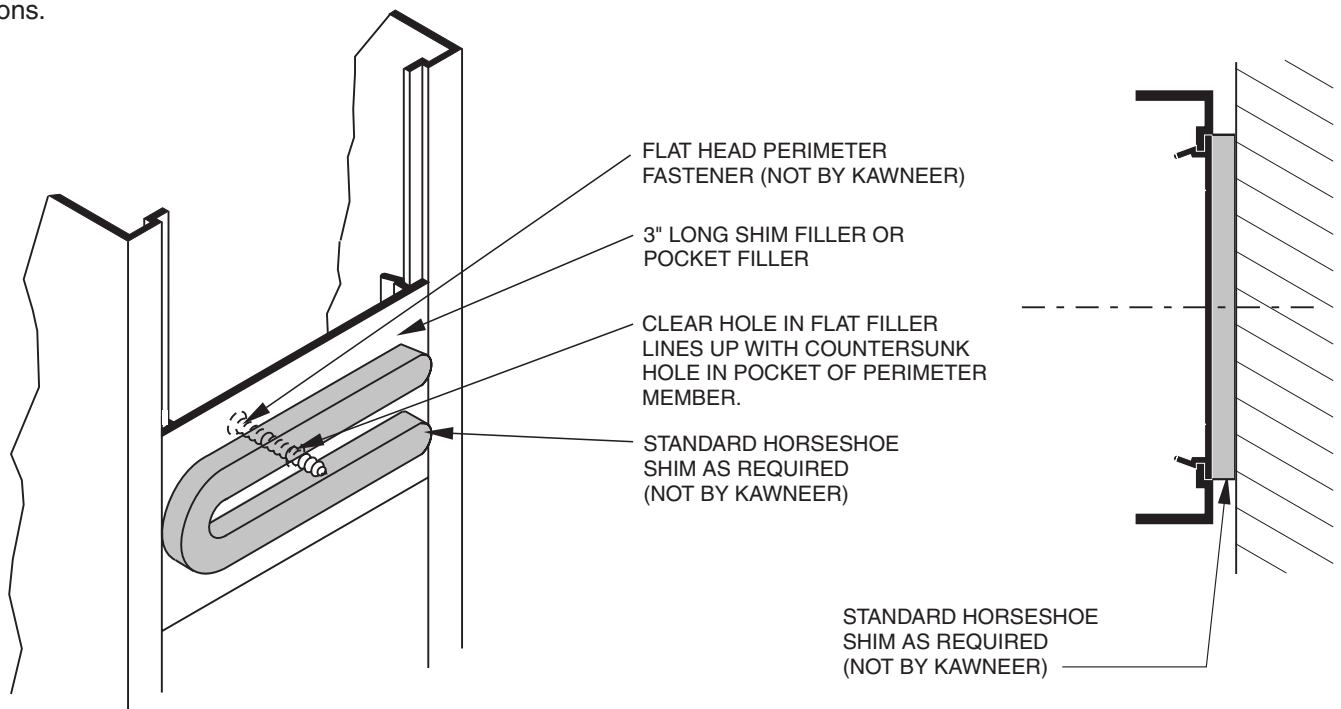

SECTION VII - INSTALLATION

SILL FLASHING

STEP 1: Apply sealant to the upstanding leg on the flashing. (1)

STEP 2: Position the assembled frame into the opening to align with sill flashing. Seat frame tightly against back leg of flashing to ensure good seal. Insert shims as needed at head and jambs, checking that the unit is level and plumb.

STEP 3: Drill perimeter anchor holes through glass pocket of frame (**DO NOT DRILL THROUGH THERMAL BREAK**). Anchor holes should be located within 6" of each side of vertical mullions and 24" O.C. between. Jambes should be anchored within 6" of head and sill and 24" O.C. between. Countersink all screw heads.

Force sealant into hole for sill perimeter fastener. (2) Coat fastener threads and shank with sealant prior to installing. (3) Seal over heads of fasteners at sill. (4)

NOTE: If heavy mullion or steel reinforcing is used, extra perimeter fasteners may be required to handle larger loads. Consult Area Application Engineering Department.

STEP 4: Caulk both interior and exterior at head, jambs and under sill flashing with a high quality sealant.

Do not caulk between sill member and sill flashing to allow water drainage. (5)

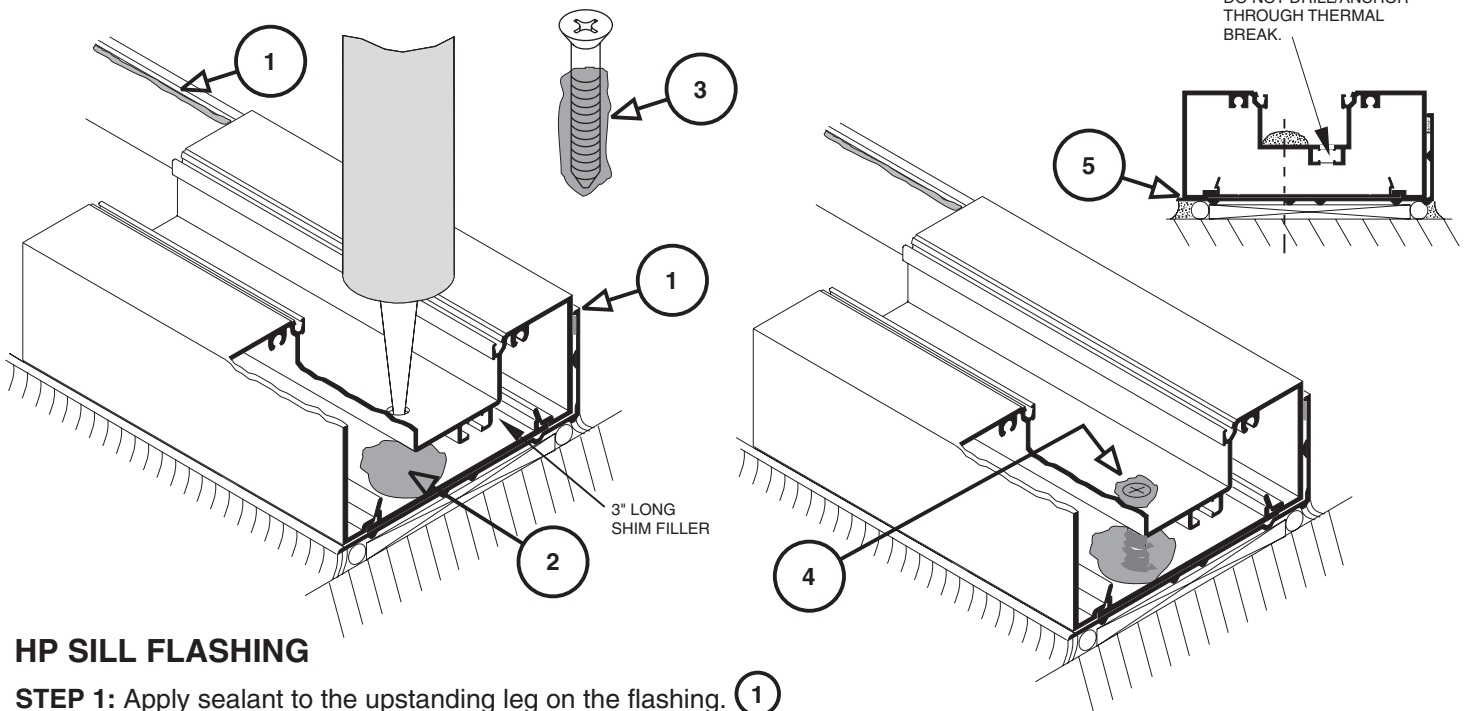

HP SILL FLASHING

STEP 1: Apply sealant to the upstanding leg on the flashing. (1)

STEP 2: Install HP interlocking sill clip into sill on each side of the vertical and crimp in place to prevent sliding. (6)

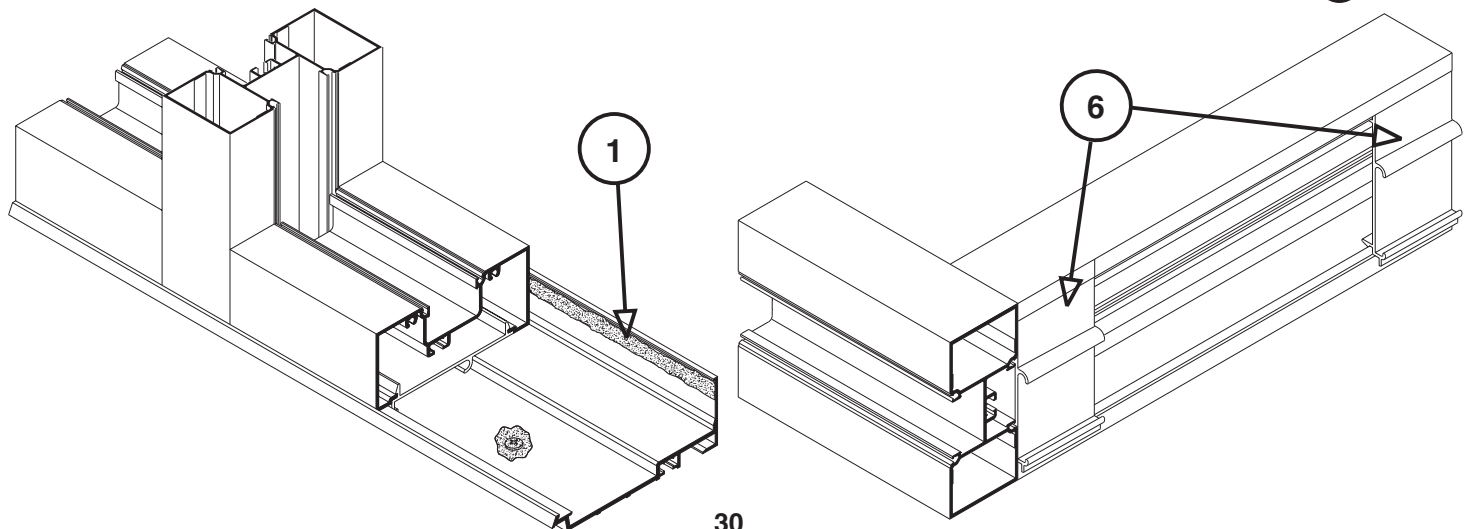

SECTION VII - INSTALLATION

HP SILL FLASHING

STEP 3: Position assembled frame onto sill tilted out at approximately 20 degrees. Allow the interlocking sill clip to engage with the lug of the flashing, and rotate to vertical position. (Figure 1)

NOTE: If heavy mullion or steel reinforcing is used, extra perimeter fasteners may be required to handle larger loads. Consult area Application Engineering.

STEP 4: Caulk both interior and exterior at head, jamb and under sill flashing with high quality sealant. Do not block weep holes in flashing.

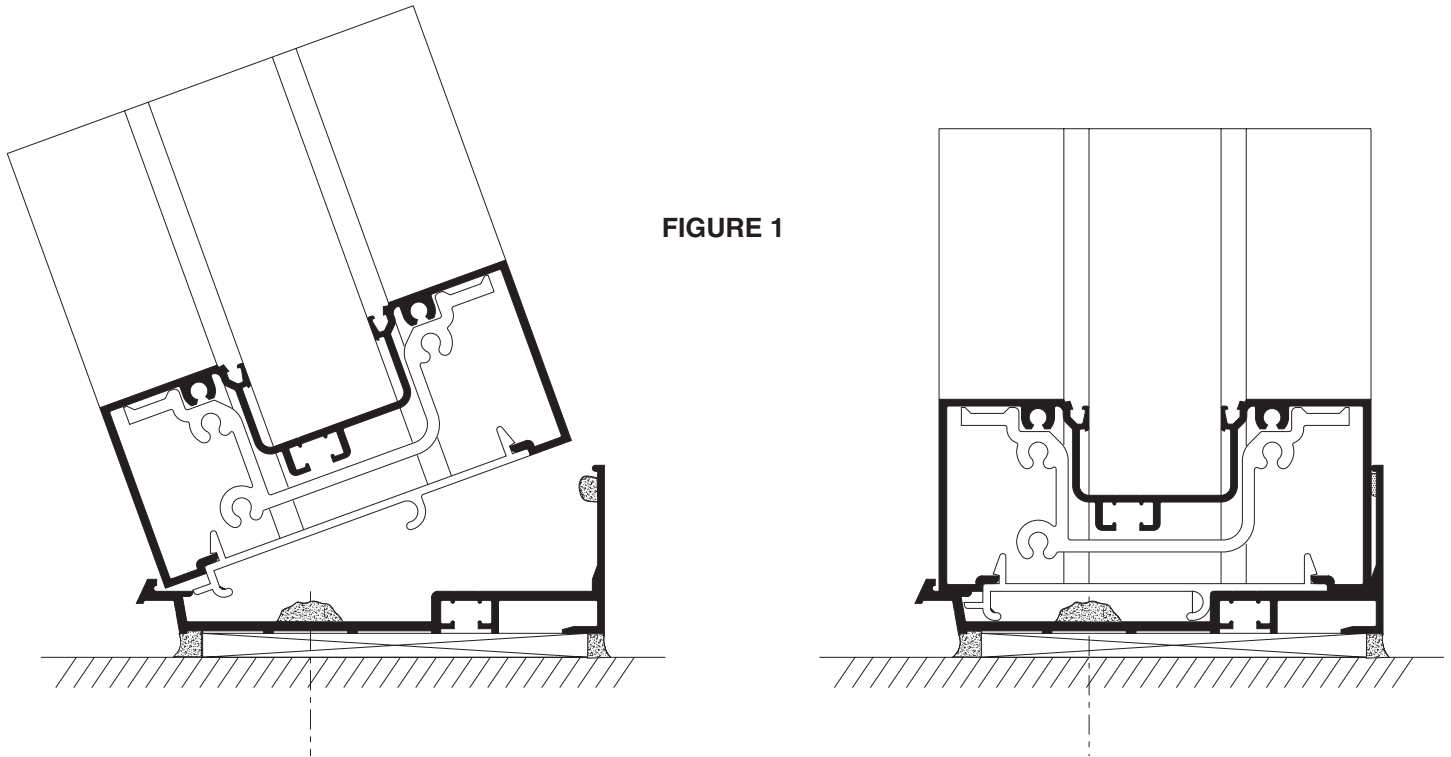
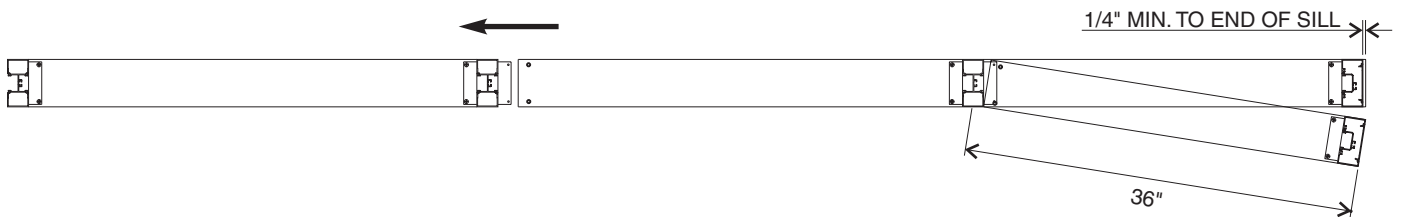

FIGURE 1

NOTE:
Last bay will NOT have
451-HP-126 interlocking sill clips.

NOTE:
HP flashing must extend beyond the
edge of the frame by 1/4" minimum.



LAST BAY NOTE:
If the last bay is less than 36" width, a larger clearance will be required at the jamb, or you may pre-assemble it with the previous bay and install as one unit.

ROTATE LAST PANEL
INTO POSITION

SECTION VII - INSTALLATION

WATER DEFLECTOR

Install water deflector on Intermediate Horizontals by removing the paper backing from the water deflectors. Install them on a clean, dry surface centered in the glazing pocket and seal. (See Figure 1)

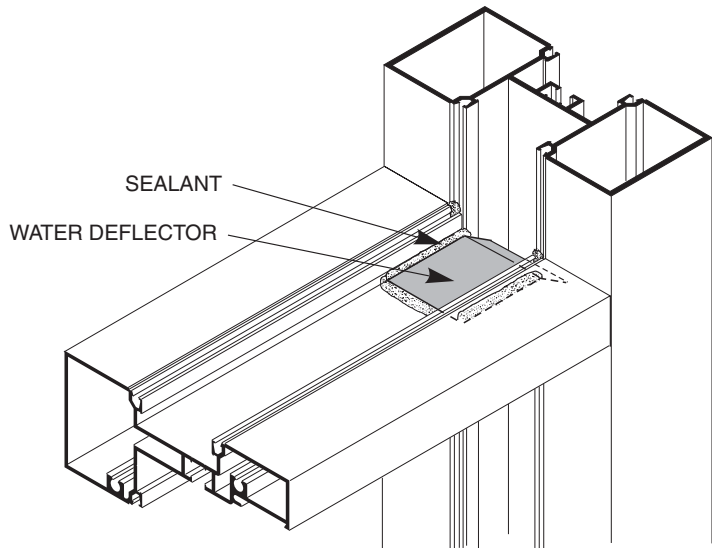

FIGURE 1

COLD WEATHER NOTE:

For temperatures below 40° the following precautions should be taken. Just prior to installing the water deflector, wipe glazing pocket with a solvent or cleaning solution recommended by the manufacturer.

*CAUTION: Carefully follow the recommendations contained in the material safety data sheet provided by the solvent/cleaning solution manufacturer regarding health and fire/explosion risks.

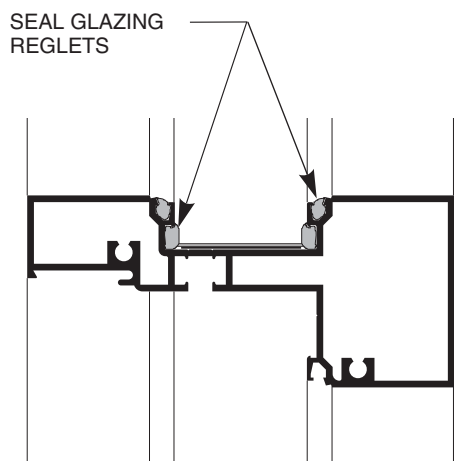
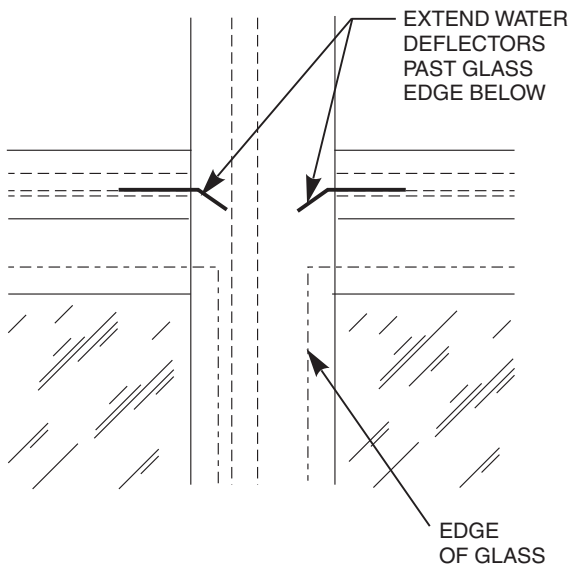

FIGURE 2

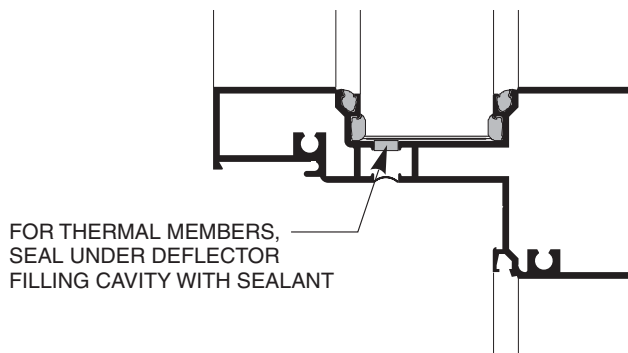

FIGURE 2

After the water deflector is installed, seal the joint between the back leg of the Horizontal and the Vertical. Make sure to fill the glazing reglets in that area to prevent water from running down to the lite below. (See Figure 2)

SECTION VIII - GLAZING ADAPTERS

GLAZING ADAPTERS FOR TRIFAB VG 451/451T

TYPICAL INSTALLATION OF PARTIAL OR FULL LENGTH VERTICAL GLAZING ADAPTERS - PRIOR TO FRAME ASSEMBLY

Vertical glazing adapters may be installed for partial, (**Figure 1**) or full-length, (**Figure 2**) applications at the time the frames are assembled.

STEP 1: Cut VERTICAL glazing adapters to D.L.O. Plus 1/2" for partial length applications or to Vertical member length for full-length applications.

STEP 2: Cut HORIZONTAL glazing adapters to D.L.O.

STEP 3: Snap vertical adapters into glazing reglets of frame and assemble frame as instructed. In partial length applications, vertical adapter should be positioned to allow sealing of the horizontal adapter to the vertical adapter (approximately 1/4" projection into horizontal pocket, **Figure 3**). It may be necessary to lightly crimp vertical adapter in place to prevent sliding.

SPECIAL NOTE: When using pre-installed vertical glazing adapters, care should be taken at the time of the frame assembly, to seal the vertical glazing reglets where they meet the intermediate horizontals. The 1/4" water deflector should also be used on all full-length applications (**Figure 4**), and installed as shown in **Section VII**. 1" water deflectors are used for partial adapter applications as long as the adapter does not impede water evacuation of the intermediate horizontal. The water deflector must allow water to drain into the vertical pocket *beyond* the edge of the glass below.

STEP 4: Apply sealant to vertical adapter at the final position of the snapped-in horizontal adapter.

STEP 5: Snap the HORIZONTAL glazing adapters into the glazing reglet allowing the adapter to rotate into the pocket and contact the sealant at the vertical adapter.

INSTALLATION OF GLAZING ADAPTERS - AFTER FRAME ASSEMBLY AND FOR FIELD RETROFIT APPLICATIONS

STEP 1: Cut VERTICAL glazing adapters to D.L.O. + 1/2".

STEP 2: Make a 1/4" by 1/4" notch at each end of the vertical glazing adapter. Notch should be made on the face side of the adapter nearest the gasket reglet as shown. (**Figure 5**)

STEP 3: Cut HORIZONTAL glazing adapters to D.L.O.

STEP 4: Snap vertical adapters into glazing reglets of frame. Adapter should be positioned to allow sealing of horizontal adapter to the vertical adapter (approximately 1/4" projection into horizontal pocket, **Figure 3**)

SPECIAL CARE NOTE: Care should be taken to insure that the glazing adapter does not impede water evacuation at the intermediate horizontal. The previously installed 1" water deflector must allow water to drain into the vertical pocket *beyond* the edge of the glass below.

STEP 5: Apply sealant to vertical adapter at the final position of the snapped-in horizontal adapter.

STEP 6: Snap the HORIZONTAL glazing adapters in the glazing reglet allowing the adapter to rotate into the pocket and contact the sealant at the vertical adapter.

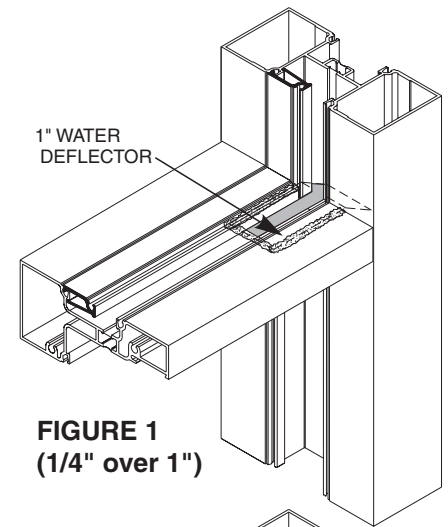

FIGURE 1
(1/4" over 1")

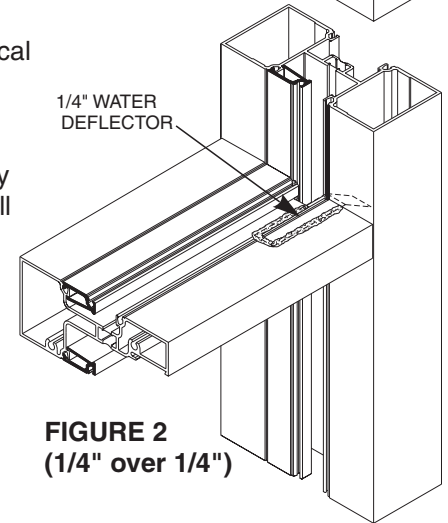

FIGURE 2
(1/4" over 1/4")

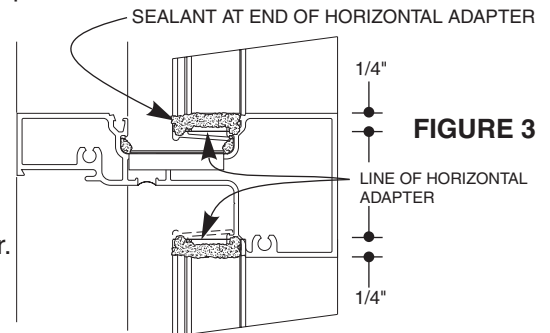

FIGURE 3

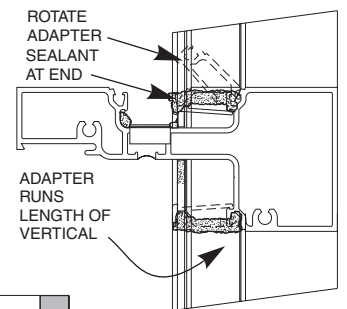

FIGURE 4

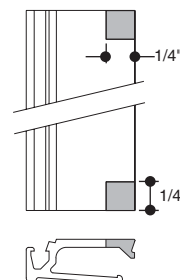

FIGURE 5

SECTION IX - GLAZING

STEP A: All pockets for 1" infill are 1-3/8" in width and will accept up to 1-1/8" glass dry glazed.
 All pockets for 1/4" infill are 5/8" in width, and will accept up to 3/8" glass dry glazed.

STEP B: Glass size is (Daylight Opening) D.L.O. + 3/4".

NOTE 1: This formula does not allow for undersize or out of square daylight openings.

NOTE 2: The glass manufacturer must indicate the specific glazing requirements for the material being used.

NOTE 3: See pages 37 or 40 for Dart Corner glass sizes.

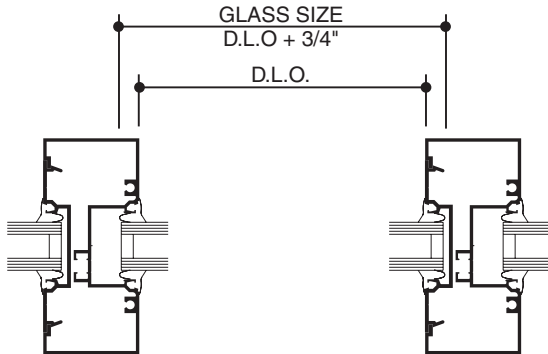
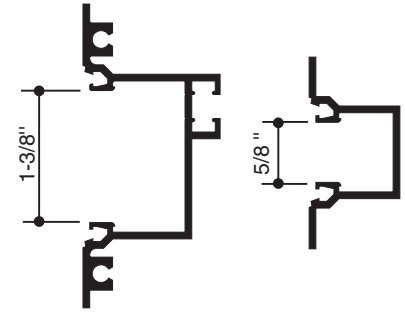

GLAZING CHART for 1/4" SYSTEM

Infill Thickness	Weathering (Both Sides)
1/8"	27-077 (Heavy)
1/4"	27-074 (Standard)
3/8"	27-076 (Light)

GLAZING CHART for 1" SYSTEM

Infill Thickness	*Adapter	Weathering (Both Sides)
1/8"	451-VG-029	27-077 (Heavy)
1/4"	451-VG-029	27-074 (Standard)
3/8"	451-VG-029	27-076 (Light)
1/2"	451-VG-030	27-077 (Heavy)
5/8"	451-VG-030	27-074 (Standard)
3/4"	451-VG-030	27-076 (Light)
7/8"	—	27-077 (Heavy)
1"	—	27-074 (Standard)
1-1/8"	—	27-076 (Light)

NOTE: For infill thickness in 1/16" increments or oversize and undersize glass, use a combination of the standard (27-074) with either the light (27-076) or heavy (27-077) gaskets.

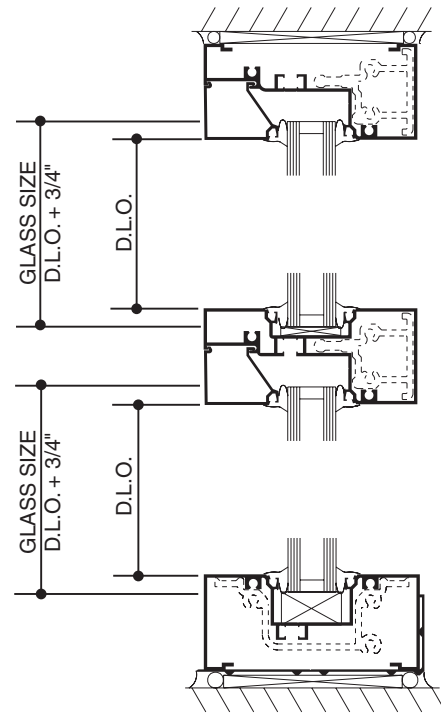

*** NOTE:**

Snap-in glazing adapters 451-VG-029 and 451-VG-030 are provided for applications requiring infills less than 1" in thickness at adaption.

Reference SECTION VIII, Glazing Adaption for adapter cut lengths and seal information.



27-077 (HEAVY)

27-074 (STANDARD)

27-076 (LIGHT)

NOTE: I.D. Marks = 3 for Heavy, 2 for Light, and none for Standard

SECTION IX - GLAZING

"W" SIDE BLOCKS

One "W" Side Block should be installed into the deep pocket of the mullion of each lite of glass in the opening.

SIDE BLOCK INSTALLATION

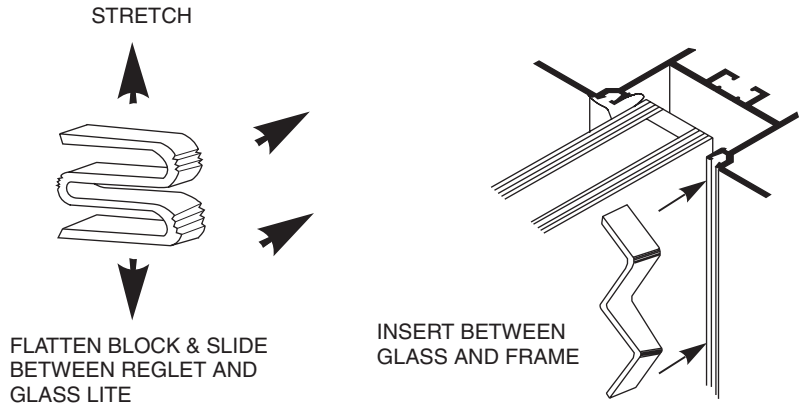
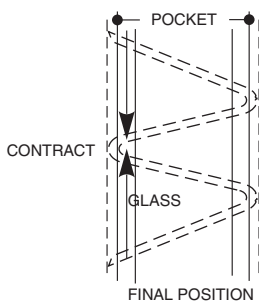
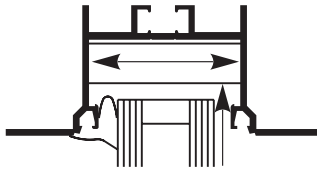

"W" Block will expand and wedge between walls of glazing pocket and prevent glass from shifting into deep pocket.

NOTE: If deglazing of lite is required after "W" Block is installed, remove both interior and exterior weathering and use hook to pull "W" Block out of the pocket.

GASKET AND GLASS STOP INSTALLATION

Step 1: Cut horizontal and vertical gaskets to an approximate length of D.L.O. + 1/4" per foot of D.L.O..

Step 2: Install gaskets on the side of frame opposite glass stops first. ①

Insert gaskets into the horizontal members first starting at the ends and work toward the center as shown. (See Figure #1)

Install vertical gaskets into the same side of frame after horizontal gaskets are in place in the same manner.

Step 3: Position setting blocks at points under glass as required.

Step 4: Install glass into frame using standard flush glazing technique. ②

Step 5: Run bead of sealant along vertical reglets where glass stop meets, then install glass stop. ③

Step 6: Install horizontal and vertical gaskets into glass stop side of frame in the same manner as described in Step #2.

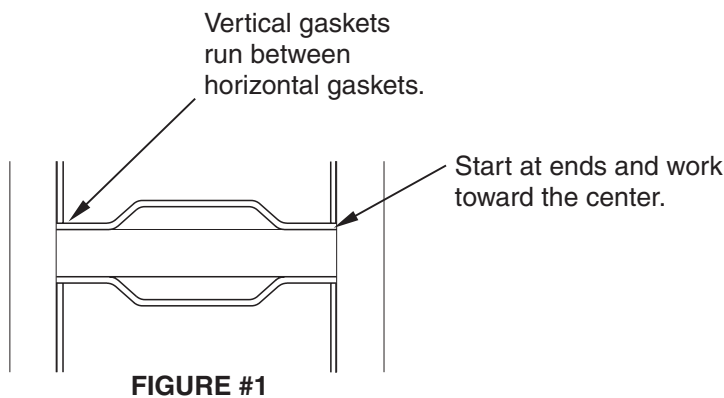
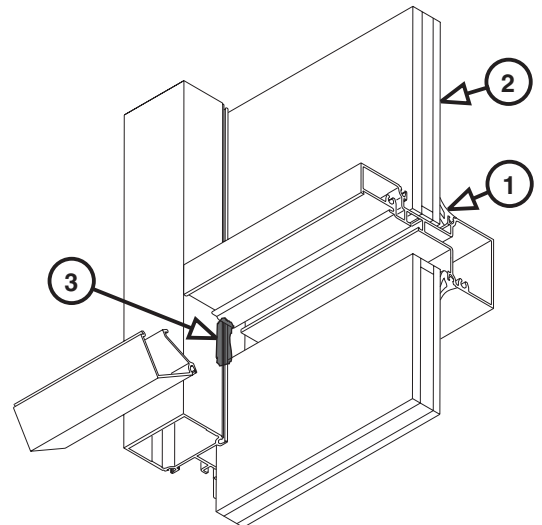

FIGURE #1



SECTION X - OPTIONAL CORNERS

ADJUSTABLE CORNERS

Use the same preps as are required for the standard vertical.

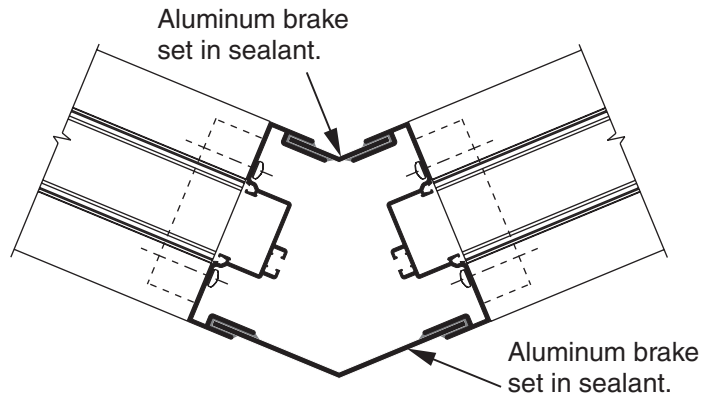

PIVOTED INSIDE AND OUTSIDE 155° to 180° CORNERS

NOTE: Layout and cut sizes can be determined using pivot center lines.

Corner parts and fabrication are the same when flipped for outside corners.

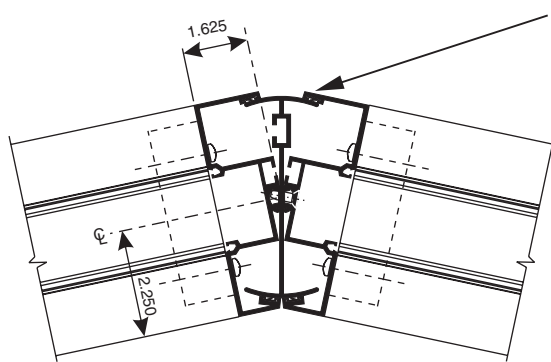

NOTE: Continuous weathering installed into both corner halves before assembly (4) places.

Use the same fabrication methods as are required for standard verticals. Drill (#26) and countersink 0.147 diameter holes for assembly screws (#10 x 9/16"). Fasten together with supplied screws. Screws should be located 6" from each end and 24" on center.

SNAP CORNERS

Snap corners together as shown

NOTE: Tight snaps may be waxed to make engagement easier. Corners are not designed to be unsnapped.

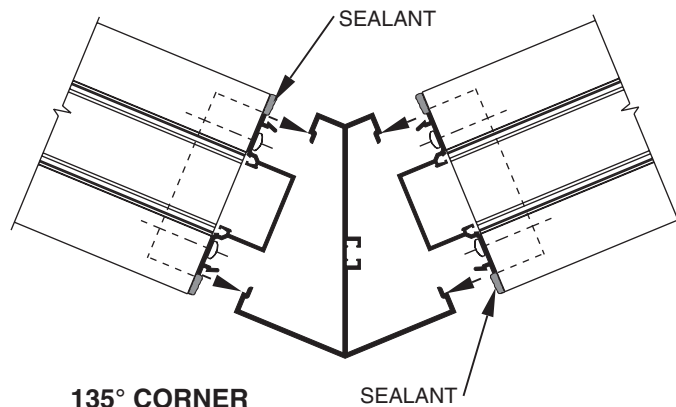
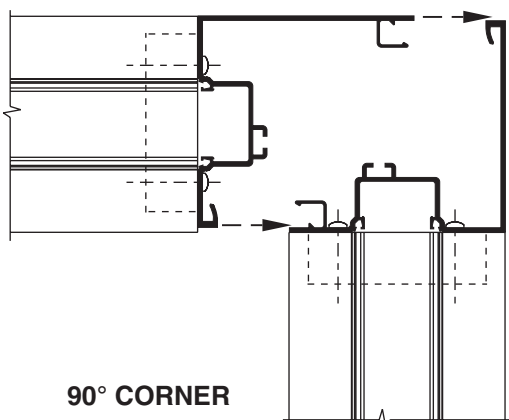

SECTION X - OPTIONAL CORNERS

90° DART CORNERS

STEP 1: Cut mullion halves and cover to required length (Frame Height).

STEP 2: Cut horizontals to length = Daylight Opening. Miter as shown on page 38 & 39.

STEP 3: Cut glass stops to D.L.O. - 1/16". Miter inside glaze glass stop as shown on page 38 & 39.

STEP 4: Drill mullion halves for shear blocks as shown below. Use the actual fabricated clip as a template.

STEP 5: Attach shear blocks using (2) #28-400 (#10 x 1-19/32") pan head screws.

STEP 6: Fabricate horizontals for (1) #128-345 (#10 x 9/16") flat head screw as shown on page 38 & 39.

TRIFAB VG 450

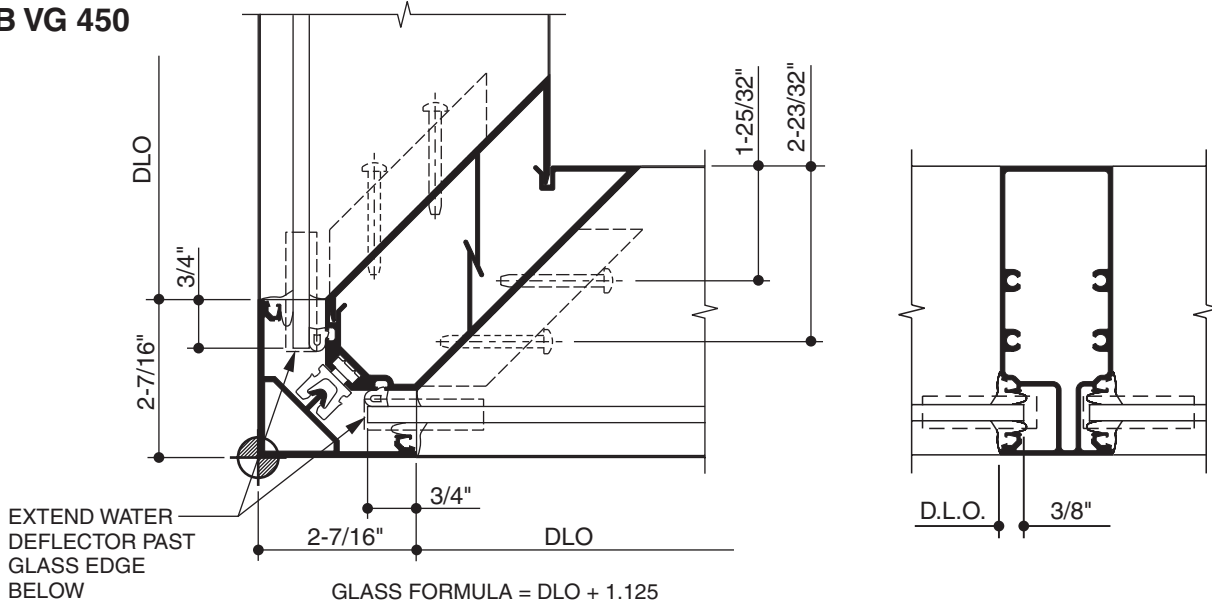

TRIFAB VG 451/451T

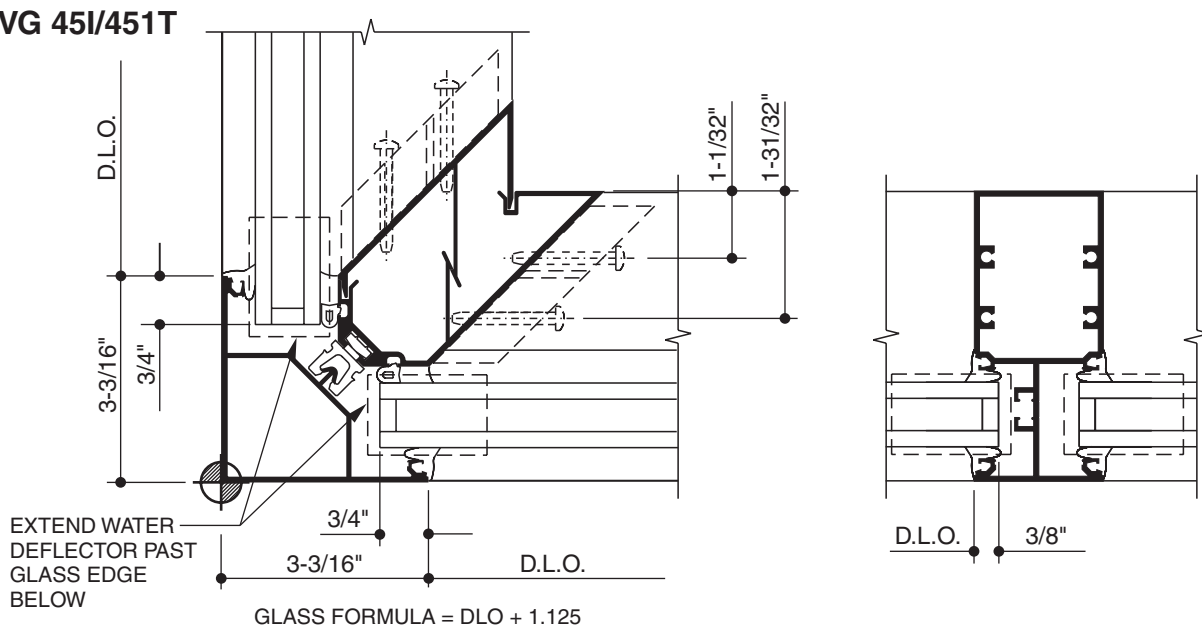

STEP 7: Prior to installing cover, install 250-299 glazing clip into vertical as shown. These clips should be located no more than 9" O.C. and no more than 3" from the ends of the mullions.

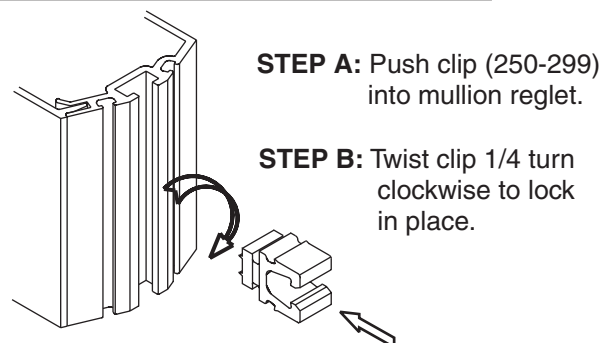

SECTION X - OPTIONAL CORNERS

90° DART CORNERS FOR TRIFAB VG 450

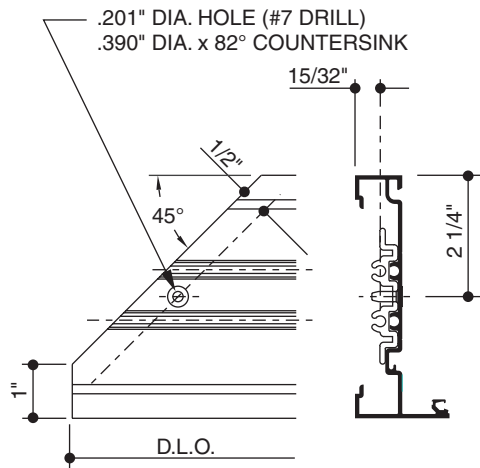

**INSIDE GLAZED HEAD
CUT LENGTH = DLO**

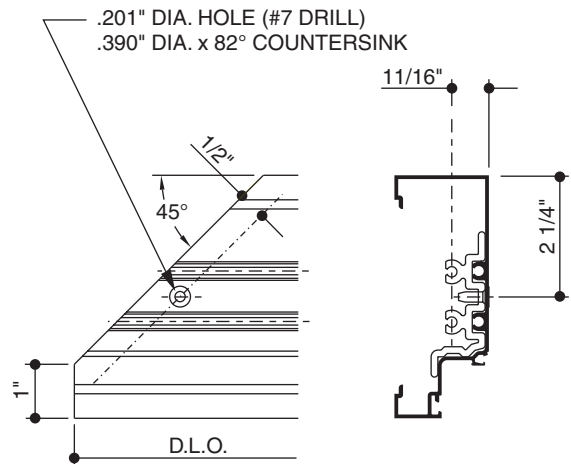

**OUTSIDE GLAZED HEAD
CUT LENGTH = DLO**

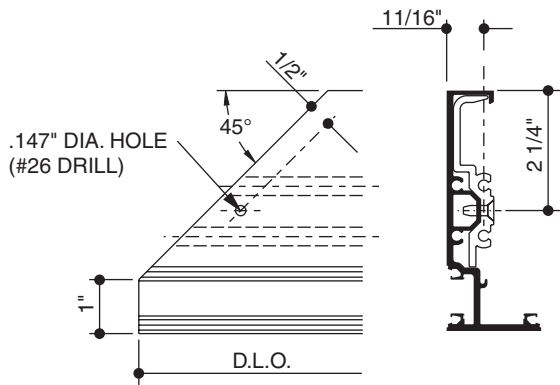

**INSIDE GLAZED HORIZONTAL
CUT LENGTH = DLO**

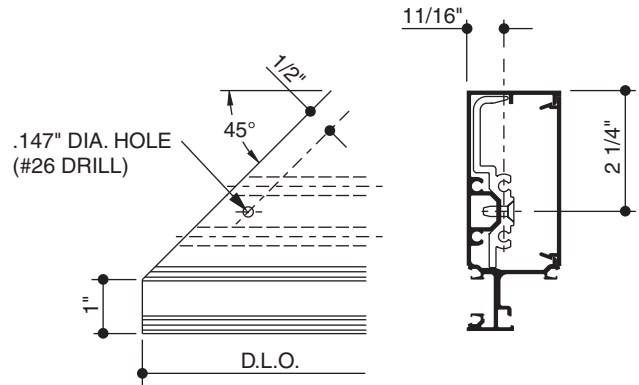

**OUTSIDE GLAZED HORIZONTAL
CUT LENGTH = DLO**

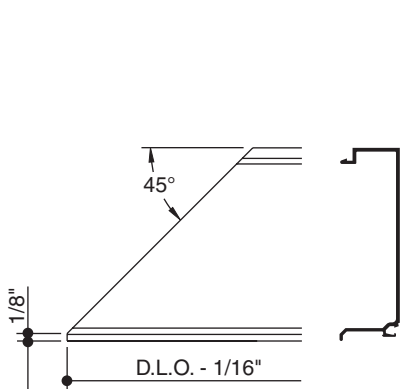

**INSIDE GLAZED GLASS STOP
CUT LENGTH = DLO - 1/16"**

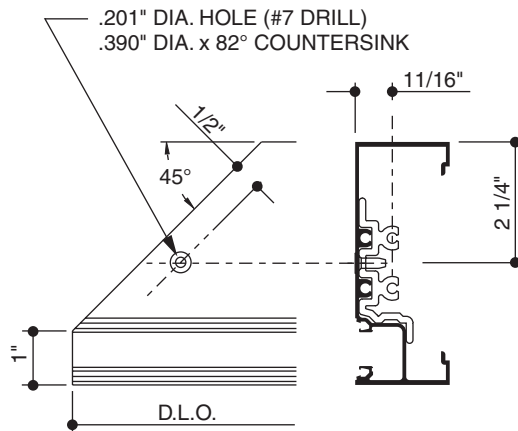

**INSIDE OR OUTSIDE GLAZED SILL
CUT LENGTH = DLO**

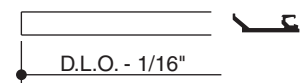

**OUTSIDE GLAZED GLASS STOP
CUT LENGTH = DLO - 1/16"**

SECTION X - OPTIONAL CORNERS

90° DART CORNERS FOR TRIFAB VG 451/451T

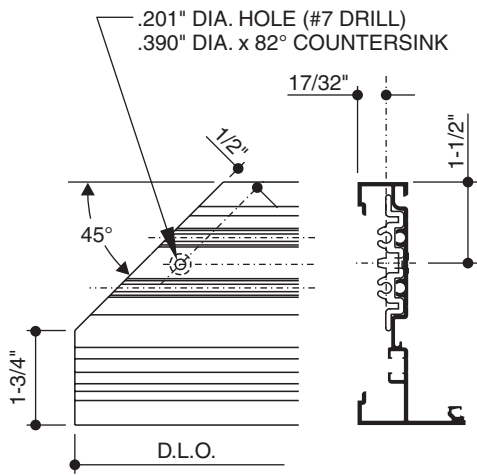

**INSIDE GLAZED HEAD
CUT LENGTH = D.L.O.**

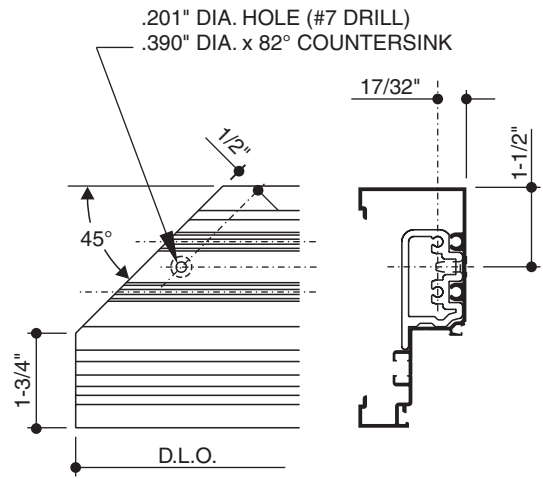

**OUTSIDE GLAZED HEAD
CUT LENGTH = D.L.O.**

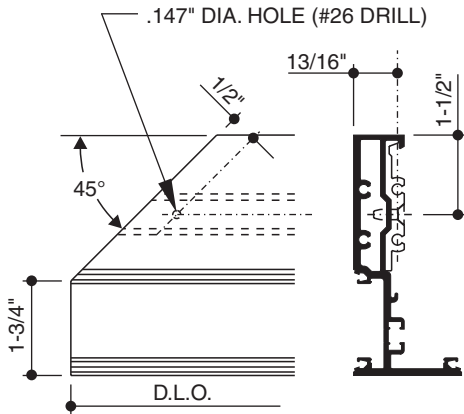

**INSIDE GLAZED HORIZONTAL
CUT LENGTH = D.L.O.**

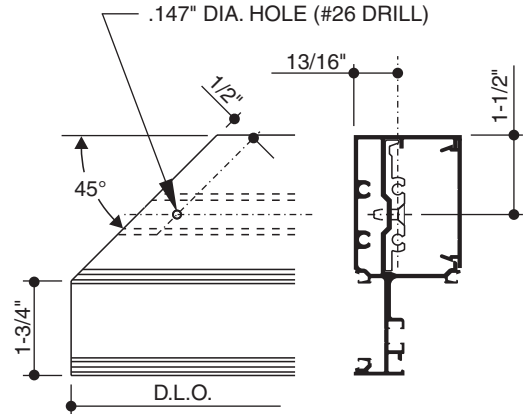

**OUTSIDE GLAZED HORIZONTAL
CUT LENGTH = D.L.O.**

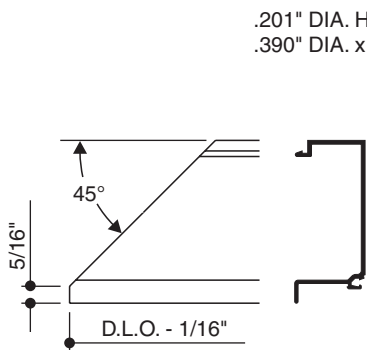

**INSIDE GLAZED GLASS STOP
CUT LENGTH = D.L.O. - 1/16"**

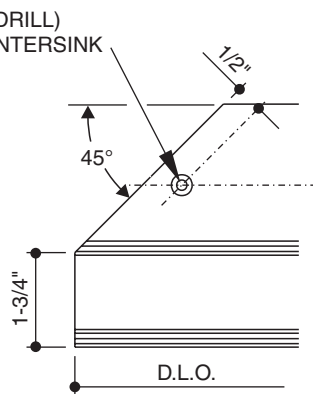

**INSIDE OR OUTSIDE GLAZED SILL
CUT LENGTH = D.L.O.**

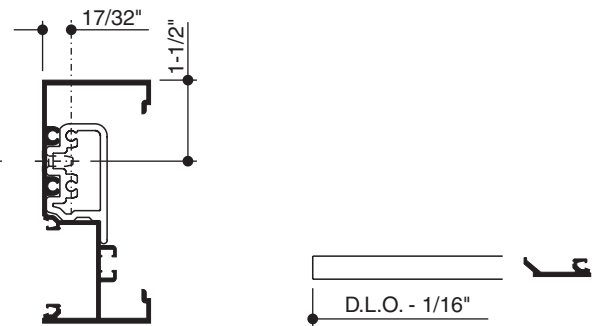

**OUTSIDE GLAZED GLASS STOP
CUT LENGTH = D.L.O. - 1/16"**

SECTION X - OPTIONAL CORNERS

135° DART CORNERS

STEP 1: Cut mullion halves and cover to required length (Frame Height).

STEP 2: Cut horizontals to length = Daylight Opening. Miter as shown on page 41 & 42.

STEP 3: Cut glass stops to D.L.O. - 1/16". Miter inside glaze glass stop as shown on page 41 & 42.

STEP 4: Drill mullion halves for shear blocks as shown below. Use the actual fabricated clip as a template.

STEP 5: Attach shear blocks using (2) #28-400 (#10 x 1-19/32") pan head screws.

STEP 6: Fabricate horizontals for (1) #128-345 (#10 x 9/16") flat head screw as shown on page 41 & 42.

TRIFAB VG 450

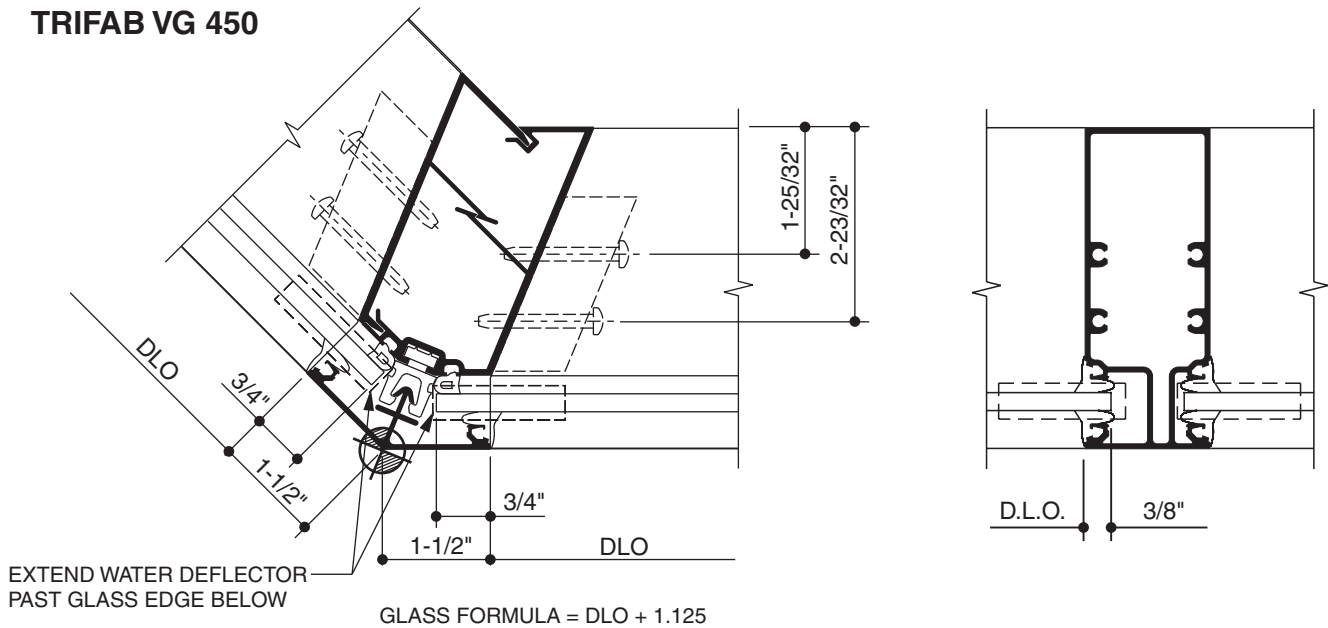

TRIFAB VG 451/451T

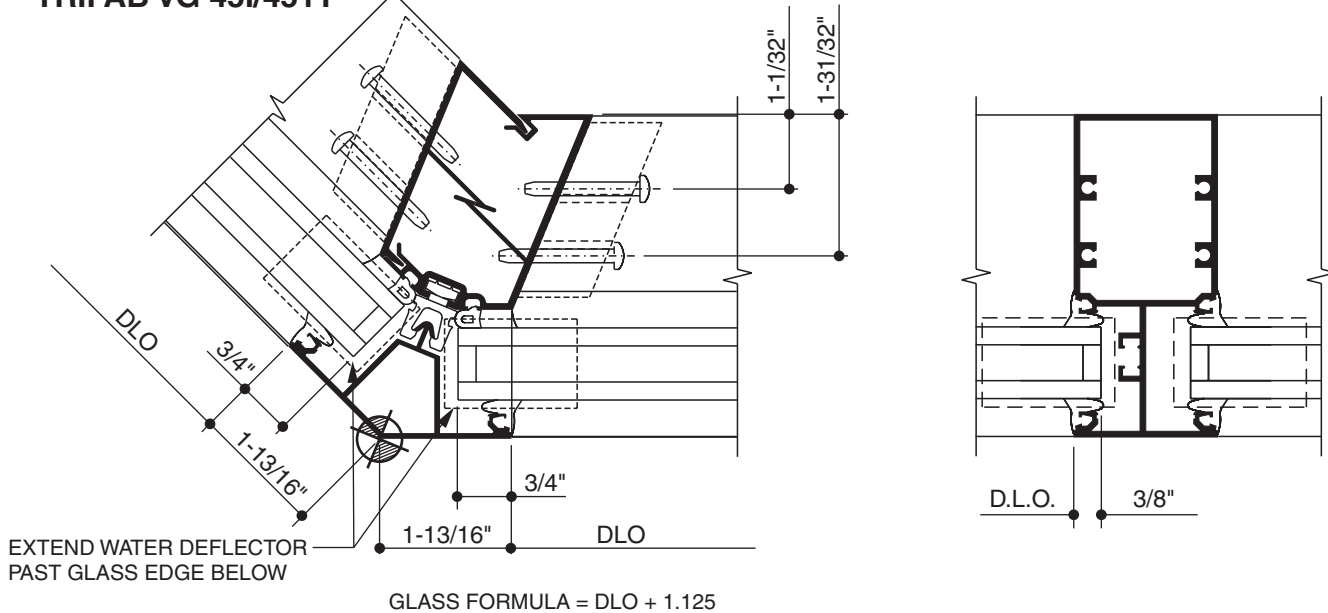

STEP 7: Prior to installing cover, install 250-299 glazing clip into vertical as shown. These clips should be located no more than 9" O.C. and no more than 3" from the ends of the mullions.

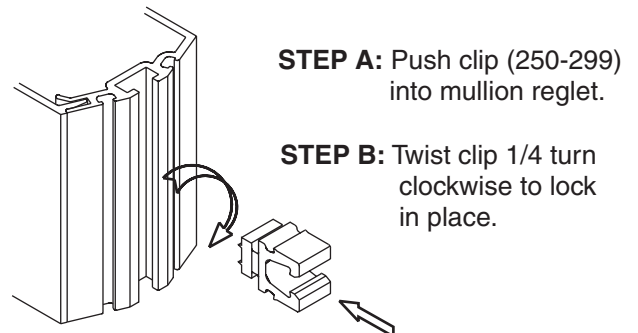

SECTION X - OPTIONAL CORNERS

135° DART CORNERS FOR TRIFAB VG 450

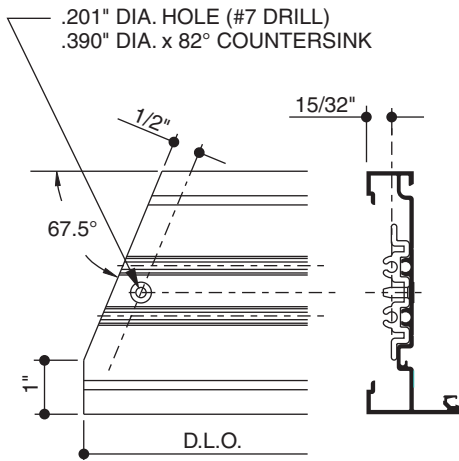

**INSIDE GLAZED HEAD
CUT LENGTH = DLO**

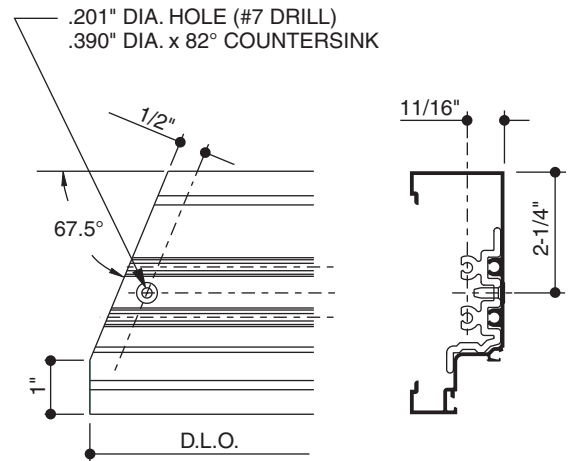

**OUTSIDE GLAZED HEAD
CUT LENGTH = DLO**

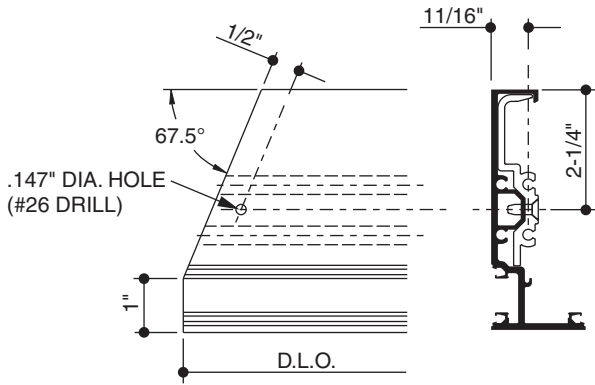

**INSIDE GLAZED HORIZONTAL
CUT LENGTH = DLO**

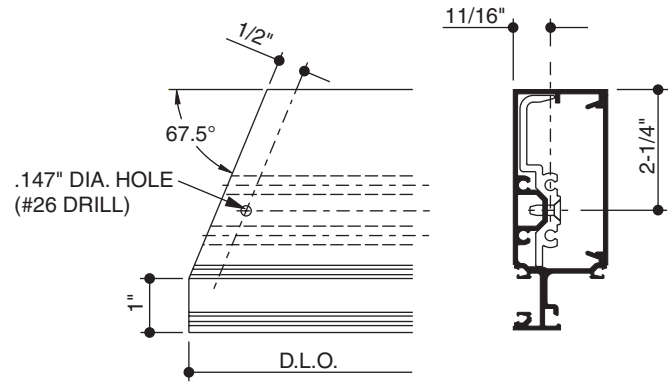

**OUTSIDE GLAZED HORIZONTAL
CUT LENGTH = DLO**

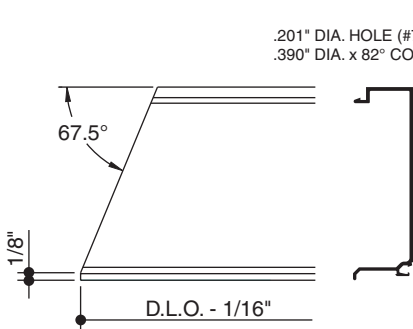

**INSIDE GLAZED GLASS STOP
CUT LENGTH = DLO - 1/16"**

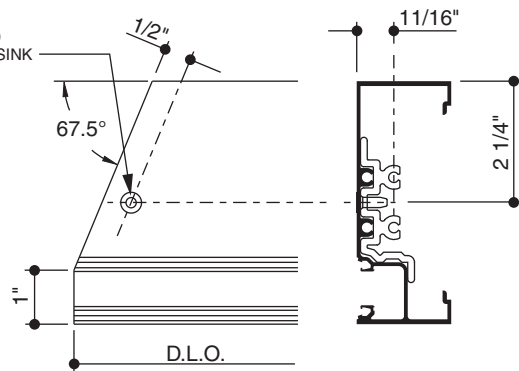

**INSIDE OR OUTSIDE GLAZED SILL
CUT LENGTH = DLO**

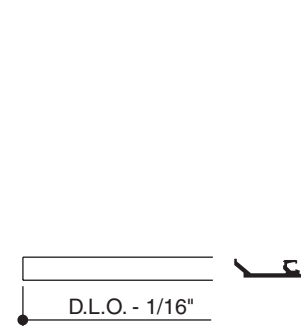

**OUTSIDE GLAZED GLASS STOP
CUT LENGTH = DLO - 1/16"**

SECTION X - OPTIONAL CORNERS

135° DART CORNERS FOR TRIFAB VG 451/451T

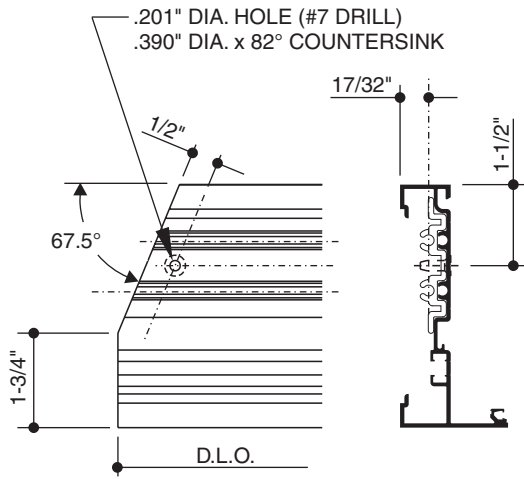

**INSIDE GLAZED HEAD
CUT LENGTH = D.L.O.**

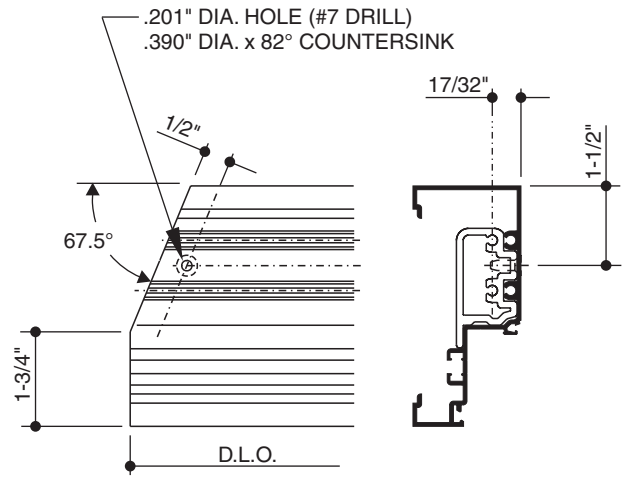

**OUTSIDE GLAZED HEAD
CUT LENGTH = D.L.O.**

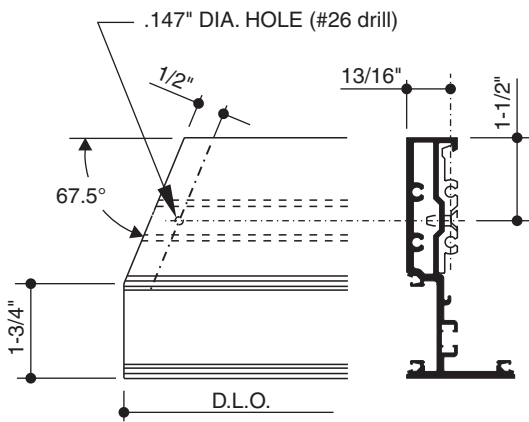

**INSIDE GLAZED HORIZONTAL
CUT LENGTH = D.L.O.**

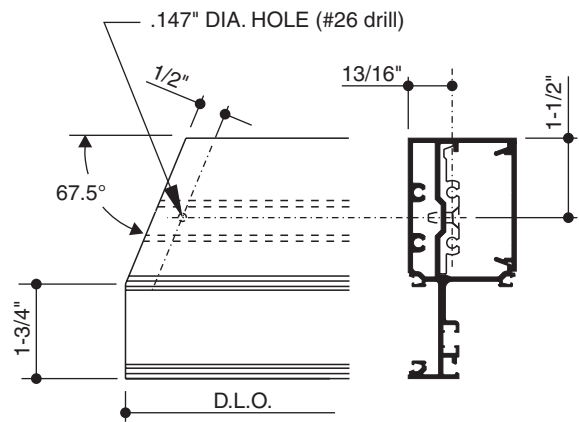

**OUTSIDE GLAZED HORIZONTAL
CUT LENGTH = D.L.O.**

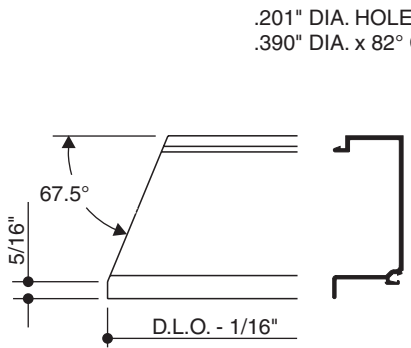

**INSIDE GLAZED GLASS STOP
CUT LENGTH = D.L.O. - 1/16"**

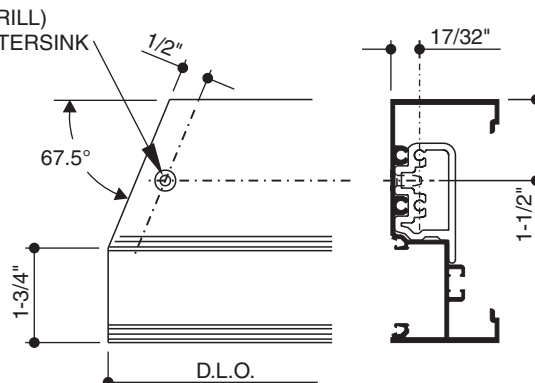

**INSIDE OR OUTSIDE GLAZED SILL
CUT LENGTH = D.L.O.**

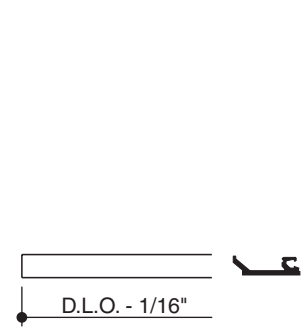

**OUTSIDE GLAZED GLASS STOP
CUT LENGTH = D.L.O. - 1/16"**

SECTION XI - EXPANSION MULLION

An Expansion Mullion is to be used every 20' in large openings, regardless of the method of construction. The dimension of the assembly should be adjusted based on the temperature at the time of assembly and expected high and low service temperatures use reference dimension. (For example, the sight line will be reduced slightly when installed in hot weather and increased slightly when installed in cold weather).



SECTION XII - STEEL REINFORCING

Steel reinforcement should run the full length of the mullion and be shimmed or fastened into place to prevent movement of the steel in the mullion. The cut ends of the steel reinforcing must be coated with a corrosion-inhibiting primer before installation.

NOTE: For Trifab VG 451 center plane applications, when steel reinforcing is required, the non-thermal split mullion without thermal pockets must be used.

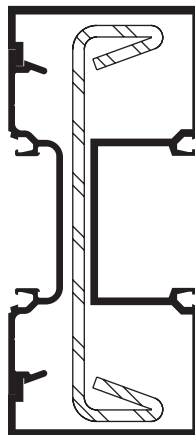

SPLIT MULLION WITH
450-110 STEEL REINFORCING

SECTION XIII - ADJUSTABLE NARROW SIDELITE BASE FOR CENTER GLAZED OPTION USING THE NON-THERMAL, 2-PIECE VERTICAL ONLY

NOTE:

Project windloads may produce end load reactions at the vertical mullions that may require additional anchors. Consult Application Engineering for review of narrow sidelite base applications.

Determine height of Sidelite Base.
Common bottom door rail heights are shown below.

STANDARD BASE

- 190 Door w/ Threshold ----- 5-1/16"
- 190 Door w/o Threshold ----- 4-9/16"

TALL BASE

- 350 & 500 Door w/ Threshold ----- 7-11/16"
- 350 & 500 Door w/o Threshold ----- 7-3/16"

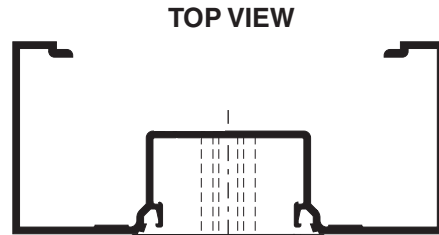
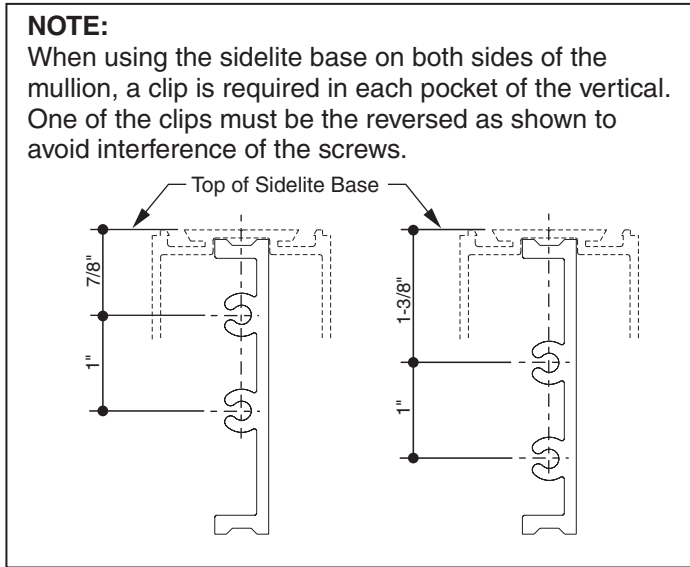
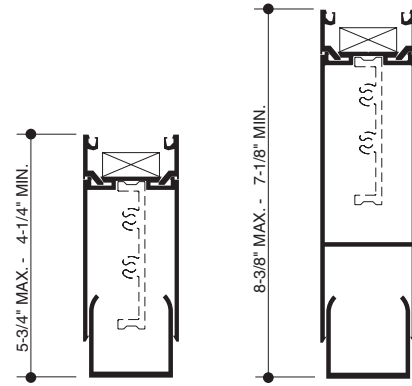

DRILL WITH #26 DRILL AND COUNTERSINK USE 128-345 SCREW CENTERED IN POCKET.

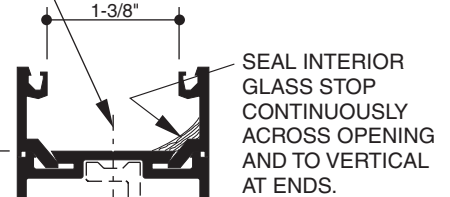

DRILL THROUGH SPLINES OF CLIP WITH #26 DRILL INTO POCKET OF VERTICAL. SECURE CLIP TO VERTICAL WITH (2) (#128-354) #10 x 2-5/8\"/>

128-345 SCREWS AT SETTING BLOCK POINTS.

1/4\"/>

SET IN BED OF SEALANT

ANCHOR TO MASONRY

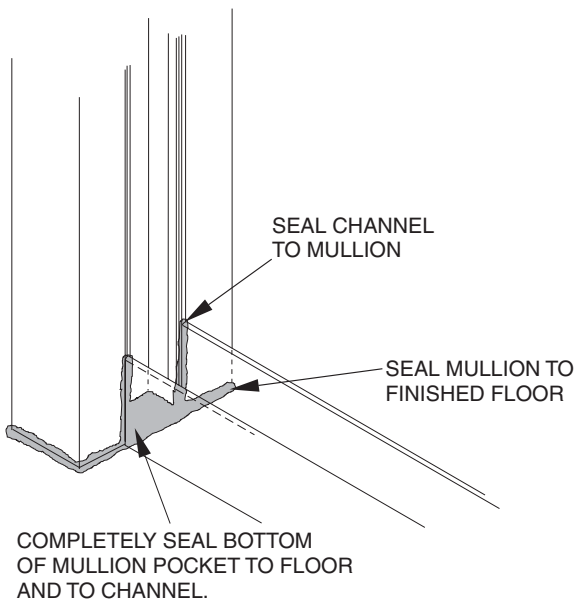

SECTION XIII - HIGH SIDELITE BASE OR HORIZONTAL FOR CENTER GLAZED OPTION

*NOTE: SILL CLIP CAN BE USED WITH ALL OPEN BACK SILL MEMBERS.

SHEAR BLOCK CENTER OPTION ONLY

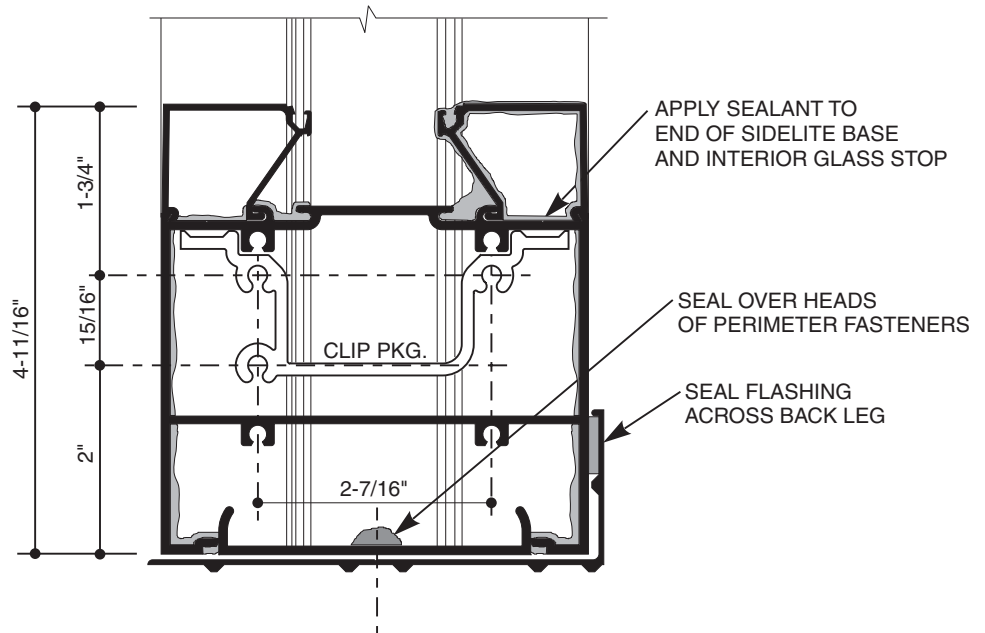
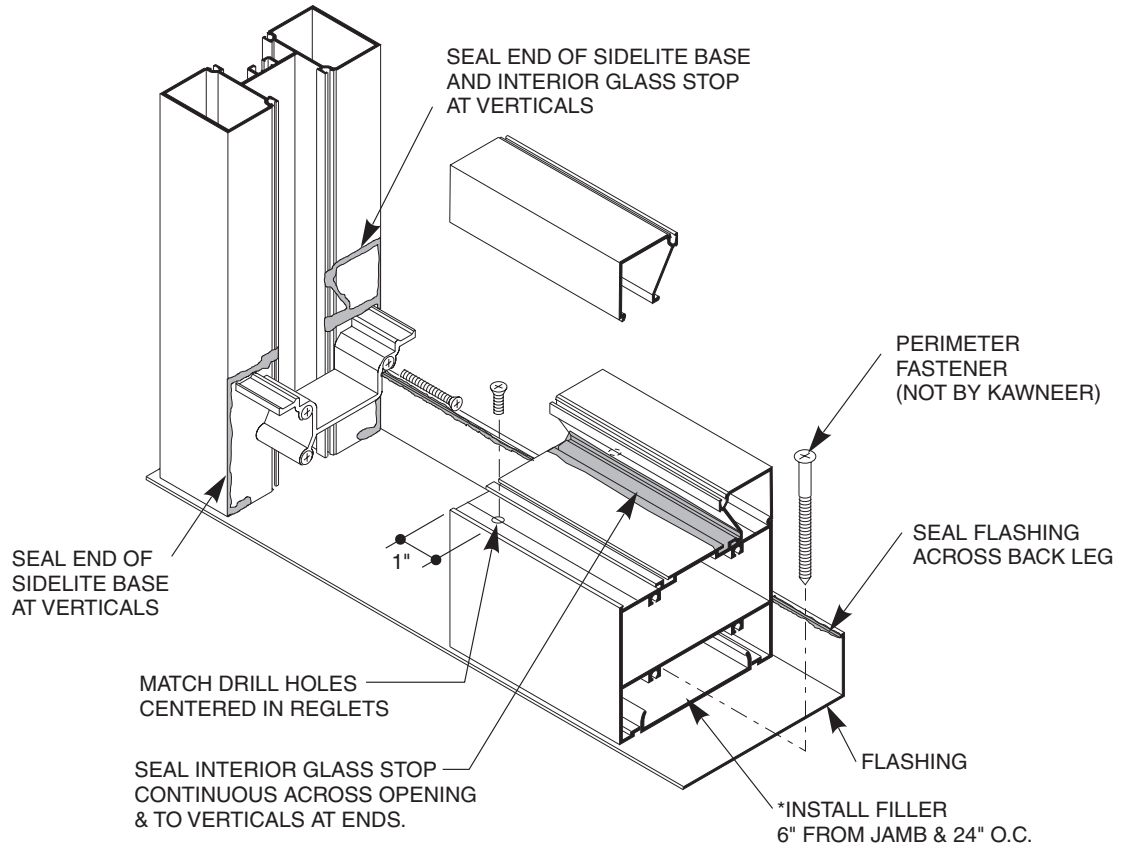

NOTES

NOTES



KAWNEER COMPANY, INC.
TECHNOLOGY PARK/ATLANTA
555 GUTHRIDGE COURT
NORCROSS, GEORGIA 30092