

990 SLIDING DOORS

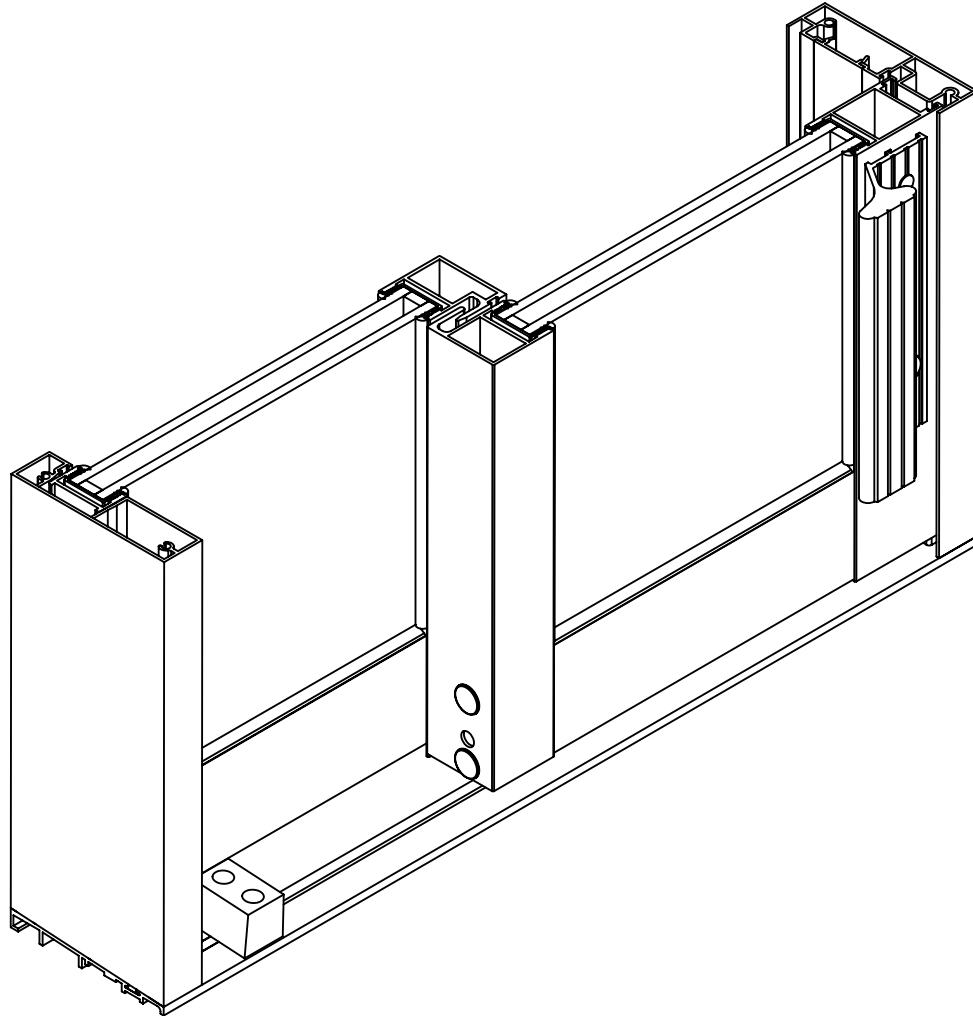

INSTALLATION INSTRUCTIONS

INSTALLATION INSTRUCTIONS CONTENTS

These instructions show the general installation sequence and procedure for typical installation. They supplement the shop details and notations on installation and glazing.

SECTION	PAGE	
I	3-4	GENERAL NOTES
II	5-8	PARTS IDENTIFICATION
III	9-12	GLASS SIZE FORMULAS
IV	13	FRAME ASSEMBLY
V	14-15	FRAME INSTALLATION
VI	16-17	PANEL GLAZING & ASSEMBLY
VII	18-20	HARDWARE INSTALLATION
VIII	21-26	PANEL INSTALLATION
IX	26-28	SCREENS

Laws and building and safety codes governing the design and use of glazed entrance, window, and curtain wall products vary widely. Kawneer does not control the selection of product configurations, operating hardware, or glazing materials, and assumes no responsibility therefor.

Kawneer reserves the right to change configuration without prior notice when deemed necessary for product improvement.
© Kawneer Company, Inc., 2009

HANDLING, STORING, AND PROTECTION OF ALUMINUM

The material must be protected against damage. The following precautions are recommended to assure early acceptance of your products and workmanship.

- A. HANDLE CAREFULLY** - Don't drop from the truck. Stack with adequate separation so material will not rub together. Store off the ground. Protect against elements and other construction trades. Wear hand protection to prevent injury due to sharp edges of cut extrusions.
- B. KEEP MATERIAL AWAY FROM WATER, MUD AND SPRAY** - Prevent cement, plaster, or other materials from damaging the finish.
- C. PROTECT THE MATERIALS AFTER ERECTION** - Protect by wrapping with Kraft paper or by erecting Visqueen or canvas splatter screen. Cement, plaster, terrazzo, other alkaline solutions and acid based materials used to clean masonry are very harmful to the finish and should be removed with water and mild soap IMMEDIATELY.

GENERAL INSTALLATION NOTES

The following practices are recommended for all installations:

- A. CHECK SHOP DRAWINGS, INSTALLATION INSTRUCTIONS and GLAZING INSTRUCTIONS** to become thoroughly familiar with the project. The SHOP DRAWINGS take precedence and include specific details for the project. The INSTALLATION INSTRUCTIONS are of a general nature and cover most common conditions.
- B. All materials are to be INSTALLED PLUMB, LEVEL, AND TRUE.**
- C. All work should start from bench marks and/or column lines as established by the ARCHITECTURAL DRAWINGS and the GENERAL CONTRACTOR.** Check mullion spacing from both ends of masonry opening to prevent dimensional build-up of day light opening.
- D. Make certain that construction which will receive your materials is in accordance with the contract documents.** If not, notify the GENERAL CONTRACTOR IN WRITING and resolve differences before proceeding with your work.
- E. Isolate all aluminum to be placed directly in contact with uncured masonry or incompatible materials with a heavy coat of zinc chromate or bituminous paint.**
- F. Check all materials on arrival for quantity and be sure you have everything required to begin installation.**
- G. Sealants must be compatible with all materials with which they have contact, including other sealant surfaces.** Consult with sealant manufacturer for recommendations relative to joint size, shelf life, compatibility, priming, tooling, adhesion, etc.
- H. FASTENING** - "Fastening" means any method of securing one part to another or to adjacent materials. These instructions specify only those fasteners used within the system. Due to varying perimeter conditions and job performance requirements, anchor fasteners are not specified in these instructions. For anchor fastening, refer to the Shop Drawings or consult the fastener supplier.
- I. CHECK OPENINGS** - Make certain that the opening which will receive your materials is in accordance with the contract documents. If not, notify the General Contractor in writing and resolve differences before proceeding with your work.
- J. BUILDING CODES** - Glass and glazing codes governing the design and use of products vary widely. Kawneer does not control the selection of product configurations, operating hardware, or glazing materials, and assumes no responsibility for these design considerations. It is the responsibility of the owner, specifier, architect, general contractor and the installer to make these selections in strict conformance with all applicable codes.
- K. EXPANSION JOINTS** - Expansion joints and perimeter seals shown in these instructions and in the shop drawings are shown at normal size. Actual dimensions may vary due to perimeter conditions and /or difference in metal temperature between the time of fabrication and time of installation. For example, a 12 foot unrestrained length of aluminum extrusion can expand or contract 3/32" over a 50° F temperature change. Any movement potential should be accounted for at the time of installation.

- L. FIELD TESTING** - It is recommended that a Water Hose Test be conducted once a sufficient portion of the framing is installed, glazed and caulked to ensure proper installation. The Water Hose Test shall be conducted in accordance with AAMA 501.2. In addition, larger projects should have periodic Water Hose Tests as additional precautionary measures.
- M. GASKET INVENTORY ROTATION** - These high quality rubber extrusions are coated with silicone lubricant. Silicone will dry over time leaving a white "chalky" residue. Please rotate your stock "FIRST IN - FIRST OUT". If the rubber becomes dry, you may use water ONE TIME to reconstitute the silicone, after that, use a soap water solution.

Laws and building and safety codes governing the design and use of glazed entrance, window, and curtain wall products vary widely. Kawneer does not control the selection of product configurations, operating hardware, or glazing materials, and assumes no responsibility therefor.

Kawneer reserves the right to change configuration without prior notice when deemed necessary for product improvement.

© Kawneer Company, Inc., 2009





















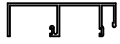

PART NO.	DESCRIPTION	ILLUSTRATION	PART NO.	DESCRIPTION	ILLUSTRATION
027-209	MARINE GLAZING GASKET - ³ / ₈ " INFILL *		420-460	HOLE PLUG	
027-210	MARINE GLAZING GASKET - ⁵ / ₈ " INFILL *		590-001	TOP RAIL - ¹ / ₄ " INFILL	
027-423	SETTING BLOCK 1- ¹ / ₈ " X ¹ / ₈ " X 4- ¹ / ₈ "		590-002	TOP RAIL - 1" INFILL	
028-270	OXO SCREEN STOB FASTENER #6 X 3/8" FHTF "B"		590-003	BOTTOM RAIL - SLIDING PANEL - ¹ / ₄ " INFILL	
028-514	#10 X ³ / ₈ " PHTF "B" PANEL ANCHOR CLIP FASTENER		590-004	BOTTOM RAIL - SLIDING PANEL - 1" INFILL	
038-324	DOOR BUMPER		590-005	BOTTOM RAIL - FIXED PANEL - ¹ / ₄ " INFILL	
127-064	TOP RAIL GUIDE		590-006	BOTTOM RAIL - FIXED PANEL - 1" INFILL	
128-267	#12 X 1" PHTF "AB" FRAME JOINERY		590-007	FIXED STILE - ¹ / ₄ " INFILL	
128-271	#12 X 5/8" PHTF "AB" PANEL BUMPER FASTENER		590-008	FIXED STILE - 1" INFILL	
128-284	#12 X 1-1/2" FHTF "AB" SILL TRACK ADAPTER TO SILL TRACK		590-015	INTERLOCK STILE - ¹ / ₄ " INFILL - STANDARD RANGE	
128-386	#12 x 2" HWHTF "B" PANEL CORNER FASTENERS		590-016	INTERLOCK STILE - 1" INFILL - STANDARD RANGE	
128-403	#12 - 24 X 9/16" FHMS ANTI-BLOWOUT CLIP FASTENER		590-017	INTERLOCK STILE - ¹ / ₄ " INFILL - MEDIUM RANGE	

* - Glass Thicknesses listed in these instructions are for nominal thickness. Actual glass thickness, especially for Laminated Glass, varies widely due to many factors. Verify the actual glass thickness with the glass manufacturer before ordering gasket to ensure the proper gasket is ordered.

Laws and building and safety codes governing the design and use of glazed entrance, window, and curtain wall products vary widely. Kawneer does not control the selection of product configurations, operating hardware, or glazing materials, and assumes no responsibility therefor.























Kawneer reserves the right to change configuration without prior notice when deemed necessary for product improvement.

© Kawneer Company, Inc., 2009

PART NO.	DESCRIPTION	ILLUSTRATION	PART NO.	DESCRIPTION	ILLUSTRATION
590-018	INTERLOCK STILE - 1" INFILL - MEDIUM RANGE		590-030	LOCK STILE - 1" INFILL - MAXIMUM RANGE FOR STANDARD LOCK	
590-019	INTERLOCK STILE - 1/4" INFILL - MAXIMUM RANGE		590-031	LOCK STILE - 1/4" INFILL - STANDARD & MEDIUM RANGE FOR MS LOCK	
590-020	INTERLOCK STILE - 1" INFILL - MAXIMUM RANGE		590-032	LOCK STILE - 1" INFILL - STANDARD & MEDIUM RANGE FOR MS LOCK	
590-021	LATCH STILE - 1/4" INFILL - STANDARD RANGE		590-033	LOCK STILE - 1/4" INFILL - MAXIMUM RANGE FOR MS LOCK	
590-022	LATCH STILE - 1" INFILL - STANDARD RANGE		590-034	LOCK STILE - 1" INFILL - MAXIMUM RANGE FOR MS LOCK	
590-023	LATCH STILE - 1/4" INFILL - MEDIUM RANGE		590-035	HORIZONTAL MUNTIN BAR - 1/4" INFILL	
590-024	LATCH STILE - 1" INFILL - MEDIUM RANGE		590-036	HORIZONTAL MUNTIN BAR - 1" INFILL	
590-025	LATCH STILE - 1/4" INFILL - MAXIMUM RANGE		590-037	HEAD TRACK	
590-026	LATCH STILE - 1" INFILL - MAXIMUM RANGE		590-038	SILL TRACK	
590-027	LOCK STILE - 1/4" INFILL - STANDARD & MEDIUM RANGE FOR STANDARD LOCK		590-039	SILL TRACK FILLER	
590-028	LOCK STILE - 1" INFILL - STANDARD & MEDIUM RANGE FOR STANDARD LOCK		590-043	STANDARD LOCK STILE MULLION	
590-029	LOCK STILE - 1/4" INFILL - MAXIMUM RANGE FOR STANDARD LOCK		590-048	FIXED JAMB	

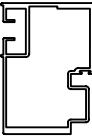
Laws and building and safety codes governing the design and use of glazed entrance, window, and curtain wall products vary widely. Kawneer does not control the selection of product configurations, operating hardware, or glazing materials, and assumes no responsibility therefor.

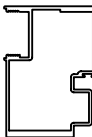

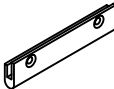











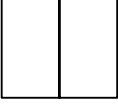





Kawneer reserves the right to change configuration without prior notice when deemed necessary for product improvement.
© Kawneer Company, Inc., 2009

PART NO.	DESCRIPTION	ILLUSTRATION	PART NO.	DESCRIPTION	ILLUSTRATION
590-049	LOCK JAMB		590-393	HEAVY DUTY MULLION REINFORCING CLIP	
590-050	EXPANSION MULLION		590-100	LOCK JAMB FILLER PLATE	
590-051	FIXED STILE MULLION		590-400	SILL TRACK FILLER	
590-088	FIXED PANEL INTERLOCK - 1/4" INFILL - STANDARD RANGE		590-401	FIXED PANEL ANCHOR CLIP	
590-089	FIXED PANEL INTERLOCK - 1" INFILL - STANDARD RANGE		590-402	CORNER REINFORCING PLATE FOR OXXO MEETING STILE	
590-090	FIXED PANEL INTERLOCK - 1/4" INFILL - MEDIUM RANGE		590-403	CORNER REINFORCING PLATE FOR OX, XO, OXO, OXXO INTERLOCK STILE	
590-091	FIXED PANEL INTERLOCK - 1" INFILL - MEDIUM RANGE		590-404	SILL ANTI-BLOWOUT CLIP	
590-092	FIXED PANEL INTERLOCK - 1/4" INFILL - MAXIMUM RANGE		590-405	ANTI-BLOWOUT CLIP REINFORCEMENT PLATE	
590-093	FIXED PANEL INTERLOCK - 1" INFILL - MAXIMUM RANGE		590-406	HEAD ANTI-BLOWOUT CLIP	
590-094	MAX RANGE LOCK STILE MULLION SINGLE GLAZE		590-411	STAINLESS STEEL TANDEM CASTER	
590-095	MAX RANGE LOCK STILE MULLION DOUBLE GLAZE		590-412	INTERLOCK BUMPER	
590-330	OXXO SCREEN STOP				

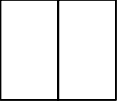
Laws and building and safety codes governing the design and use of glazed entrance, window, and curtain wall products vary widely. Kawneer does not control the selection of product configurations, operating hardware, or glazing materials, and assumes no responsibility therefor.

Kawneer reserves the right to change configuration without prior notice when deemed necessary for product improvement.

© Kawneer Company, Inc., 2009

PART NO.	DESCRIPTION	ILLUSTRATION	PART NO.	DESCRIPTION	ILLUSTRATION
590-413	STD HD SCREEN OX & OXO-L		925-464	MARINE GLAZING GASKET - $\frac{5}{16}$ " INFILL *	
590-414	STD HD SCREEN XO & OXO-R		925-536	INTERIOR 'DUMMY' PULL HANDLE	
590-415	STD HD SCREEN OXXO		925-538	ALUMINUM BAR FOR INTERIOR 'DUMMY' HANDLE (OXXO)	
590-985	FOAM/FELT AIR DAM		925-577	MARINE GLAZING GASKET - 1" INFILL *	
911-347	PANEL BUMPER		925-601	PULL HANDLE	
911-783	HEAVY DUTY SCREEN, OX & OXO-L STAINLESS STEEL HARDWARE		925-604	SCREEN JAMB FACE	
911-787	HEAVY DUTY SCREEN, XO & OXO-R STAINLESS STEEL HARDWARE		925-605	SCREEN JAMB	
911-791	HEAVY DUTY SCREEN, OXXO STAINLESS STEEL HARDWARE		925-659	SCREEN LATCH ADAPTOR	
925-325	MARINE GLAZING GASKET - $\frac{3}{16}$ " INFILL *		977-108	#10 X $\frac{1}{2}$ " PHTF STAINLESS STEEL CASTER FASTENER	
925-326	MARINE GLAZING GASKET - $\frac{7}{32}$ " INFILL *				
925-327	MARINE GLAZING GASKET - $\frac{1}{4}$ " INFILL *				
925-393	STAINLESS STEEL DOOR TRACK				

* - Glass Thicknesses listed in these instructions are for nominal thickness. Actual glass thickness, especially for Laminated Glass, varies widely due to many factors. Verify the actual glass thickness with the glass manufacturer before ordering gasket to ensure the proper gasket is ordered.

GLASS HEIGHT FORMULAS: (FOR ALL CONFIGURATIONS)

NOTES:

- 1. GLASS SIZE FORMULAS ARE BASED ON EQUAL DAYLIGHT OPENING WIDTHS.

SLIDING & FIXED PANEL
(FOR ALL CONFIGURATIONS)

$$\text{GLASS HEIGHT} = \text{FRAME HEIGHT} \text{ MINUS } 4\text{-}9/16\text{"}$$

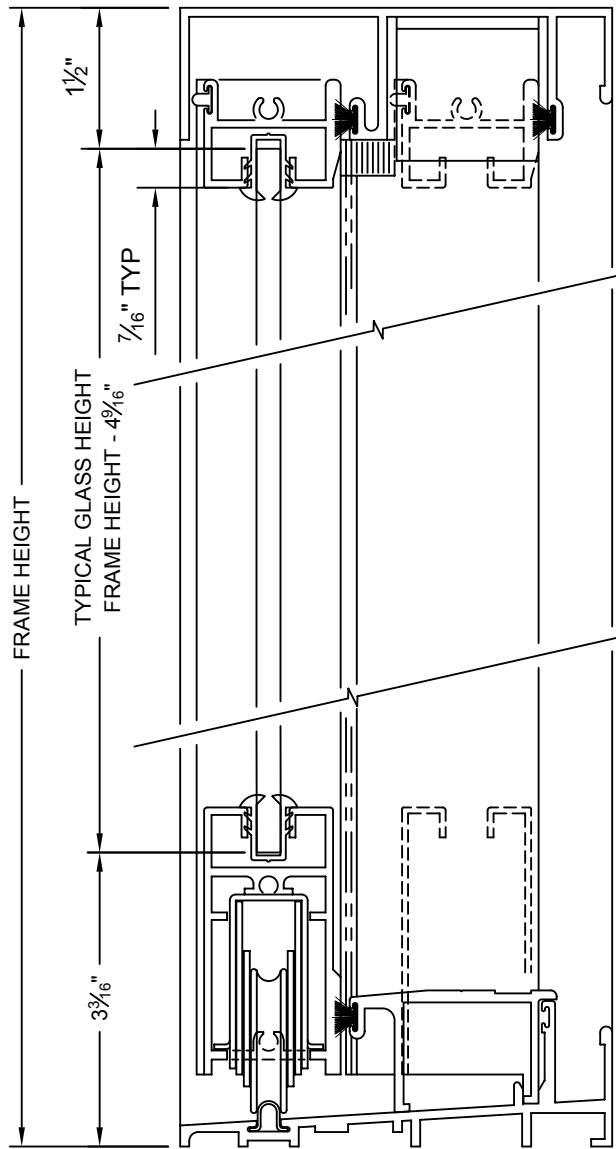

Laws and building and safety codes governing the design and use of glazed entrance, window, and curtain wall products vary widely. Kawneer does not control the selection of product configurations, operating hardware, or glazing materials, and assumes no responsibility therefor.

Kawneer reserves the right to change configuration without prior notice when deemed necessary for product improvement.

© Kawneer Company, Inc., 2009

STANDARD RANGE OX AND XO

$$\text{GLASS WIDTH FOR 1848 LATCH} = \frac{\text{FRAME WIDTH MINUS } 4 \frac{1}{4}''}{2}$$

$$\text{GLASS WIDTH FOR MS HOOKBOLT} = \frac{\text{FRAME WIDTH MINUS } 4 \frac{3}{4}''}{2}$$

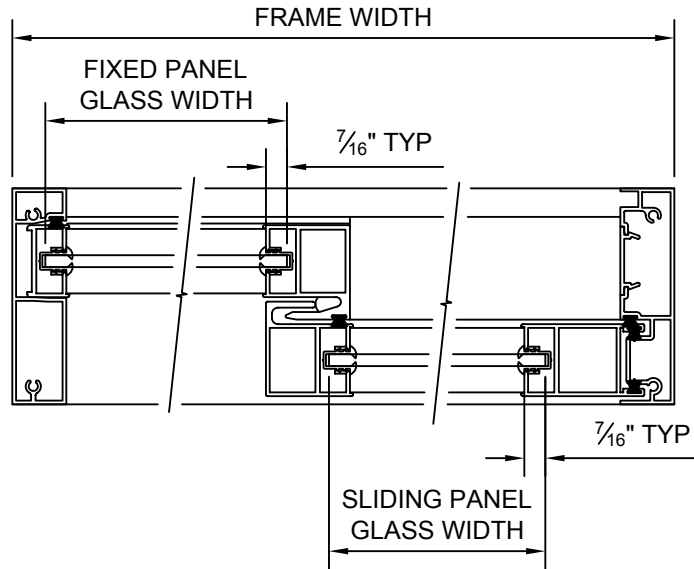

STANDARD RANGE OXO

$$\text{GLASS WIDTH FOR 1848 LATCH} = \frac{\text{FRAME WIDTH MINUS } 5 \frac{1}{8}''}{3}$$

$$\text{GLASS WIDTH FOR MS HOOKBOLT} = \frac{\text{FRAME WIDTH MINUS } 5 \frac{5}{8}''}{3}$$

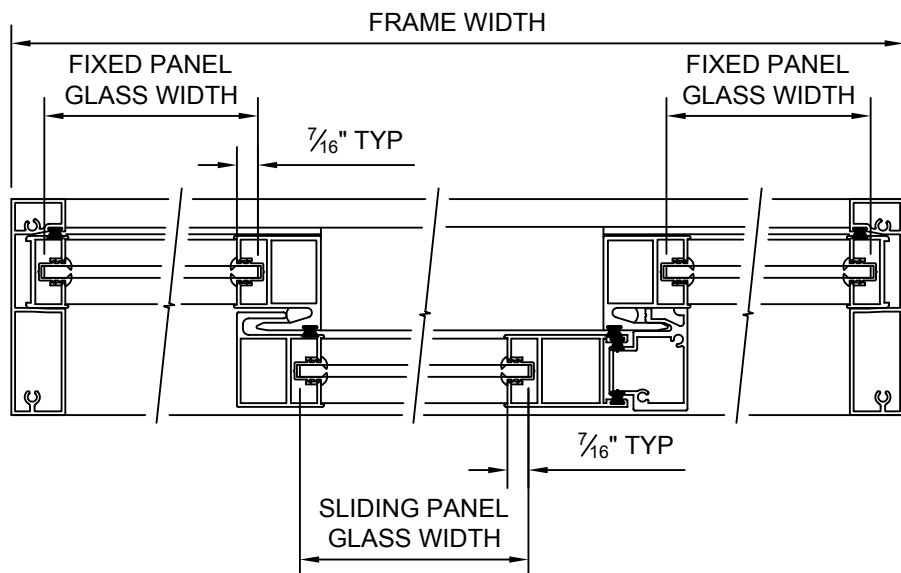

STANDARD RANGE OXXO

$$\text{GLASS WIDTH FOR 1848 LATCH} = \frac{\text{FRAME WIDTH MINUS } 6 \frac{7}{8}''}{4}$$

$$\text{GLASS WIDTH FOR MS HOOKBOLT} = \frac{\text{FRAME WIDTH MINUS } 7 \frac{3}{8}''}{4}$$

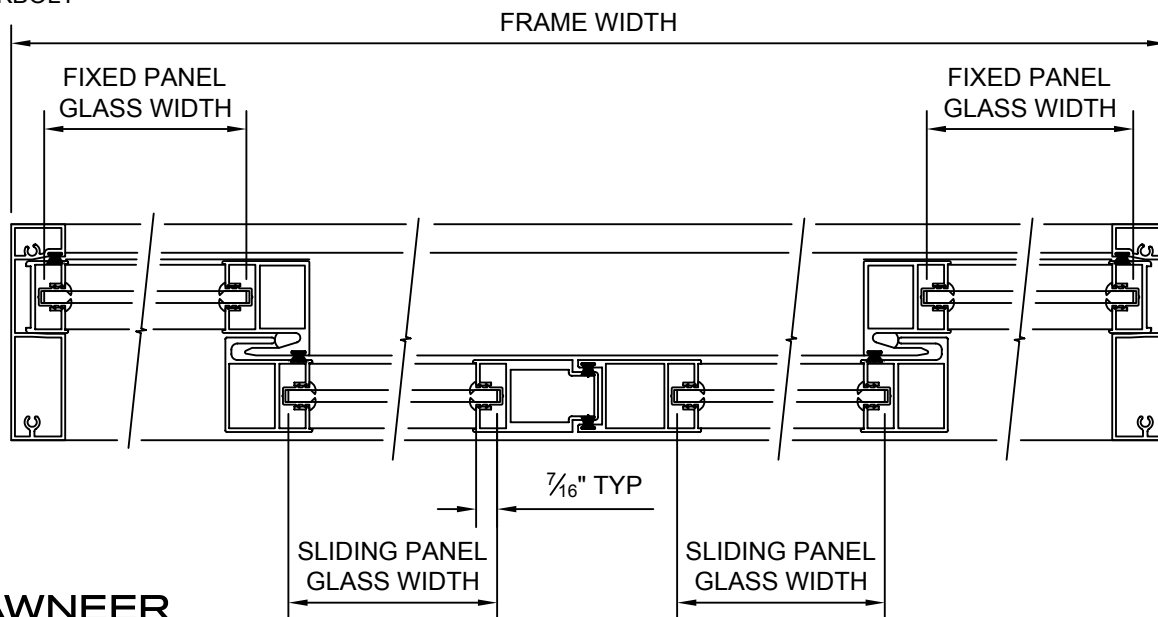

Laws and building and safety codes governing the design and use of glazed entrance, window, and curtain wall products vary widely. Kawneer does not control the selection of product configurations, operating hardware, or glazing materials, and assumes no responsibility therefor.

Kawneer reserves the right to change configuration without prior notice when deemed necessary for product improvement.
© Kawneer Company, Inc., 2009

MEDIUM RANGE OX AND XO

GLASS WIDTH FOR 1848 LATCH = $\frac{\text{FRAME WIDTH MINUS } 4 \frac{1}{4}''}{2}$

GLASS WIDTH FOR MS HOOKBOLT = $\frac{\text{FRAME WIDTH MINUS } 4 \frac{3}{4}''}{2}$

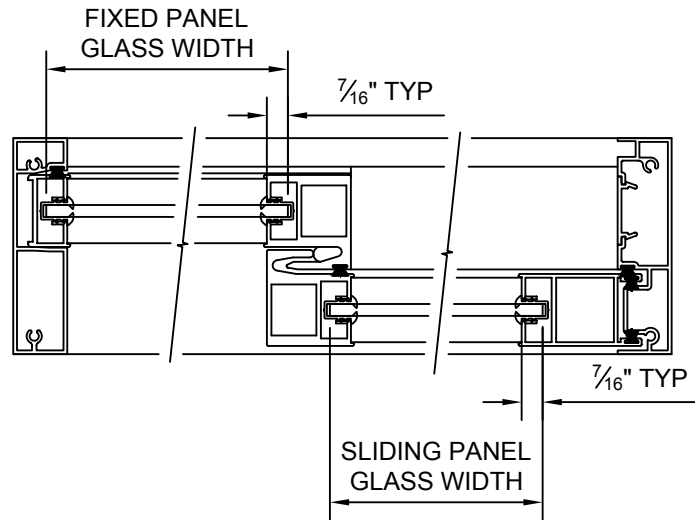

MEDIUM RANGE OXO

GLASS WIDTH FOR 1848 LATCH = $\frac{\text{FRAME WIDTH MINUS } 5 \frac{5}{8}''}{3}$

GLASS WIDTH FOR MS HOOKBOLT = $\frac{\text{FRAME WIDTH MINUS } 5 \frac{5}{8}''}{3}$

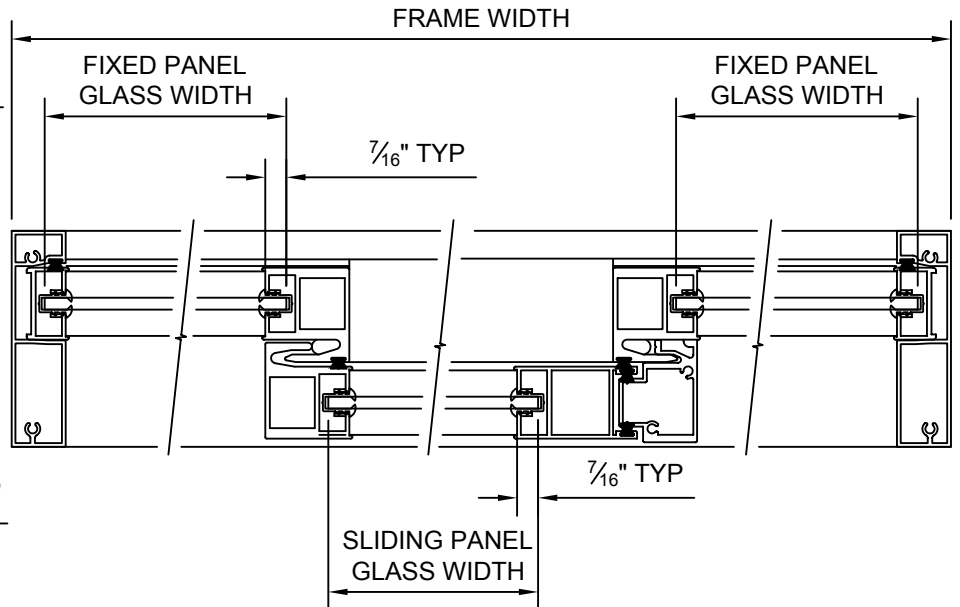

MEDIUM RANGE OXXO

GLASS WIDTH FOR 1848 LATCH = $\frac{\text{FRAME WIDTH MINUS } 7 \frac{3}{8}''}{4}$

GLASS WIDTH FOR MS HOOKBOLT = $\frac{\text{FRAME WIDTH MINUS } 7 \frac{7}{8}''}{4}$

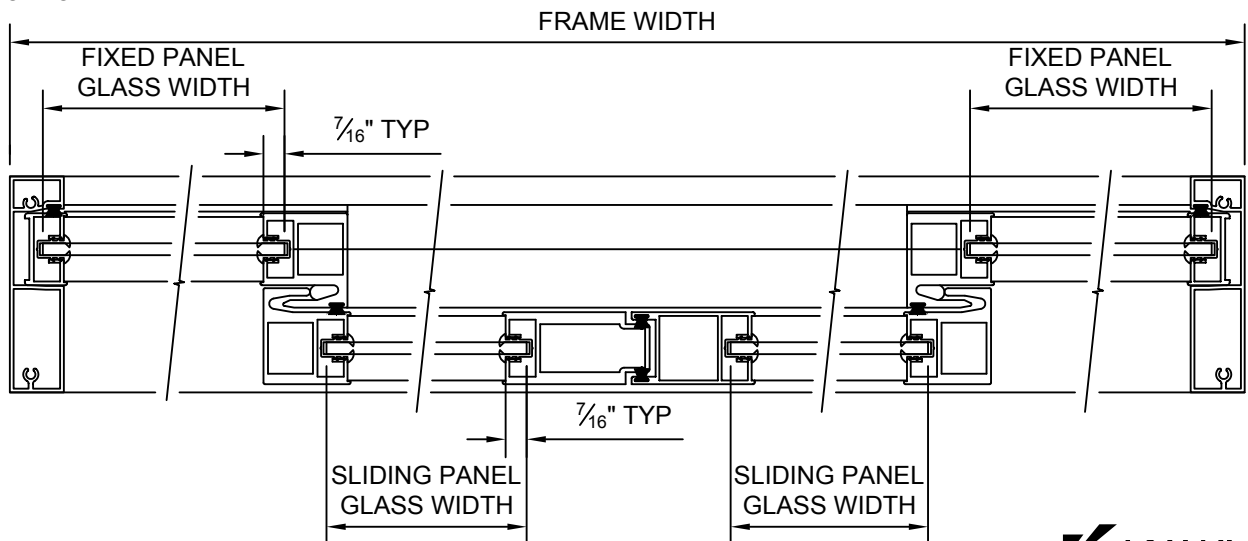

Laws and building and safety codes governing the design and use of glazed entrance, window, and curtain wall products vary widely. Kawneer does not control the selection of product configurations, operating hardware, or glazing materials, and assumes no responsibility therefor.

Kawneer reserves the right to change configuration without prior notice when deemed necessary for product improvement.

© Kawneer Company, Inc., 2009

MAXIMUM RANGE OX AND XO

$$\text{GLASS WIDTH FOR 1848 LATCH} = \frac{\text{FRAME WIDTH MINUS } 5''}{2}$$

$$\text{GLASS WIDTH FOR MS HOOKBOLT} = \frac{\text{FRAME WIDTH MINUS } 5\frac{1}{2}''}{2}$$

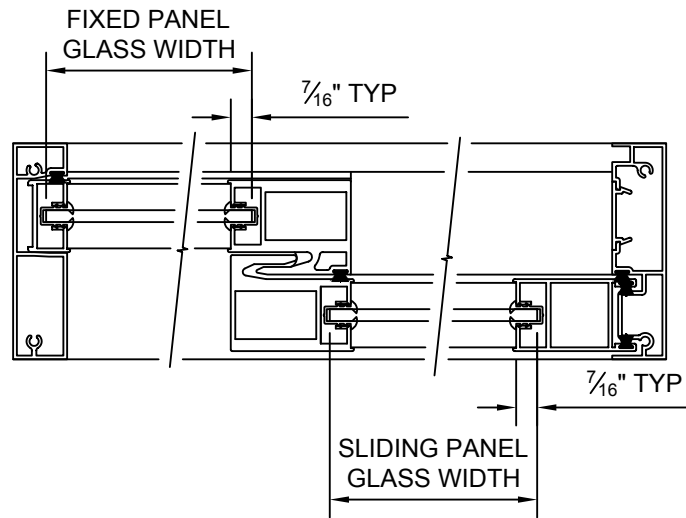

MAXIMUM RANGE OXO

$$\text{GLASS WIDTH FOR 1848 LATCH} = \frac{\text{FRAME WIDTH MINUS } 6\frac{5}{8}''}{3}$$

$$\text{GLASS WIDTH FOR MS HOOKBOLT} = \frac{\text{FRAME WIDTH MINUS } 7\frac{1}{8}''}{3}$$

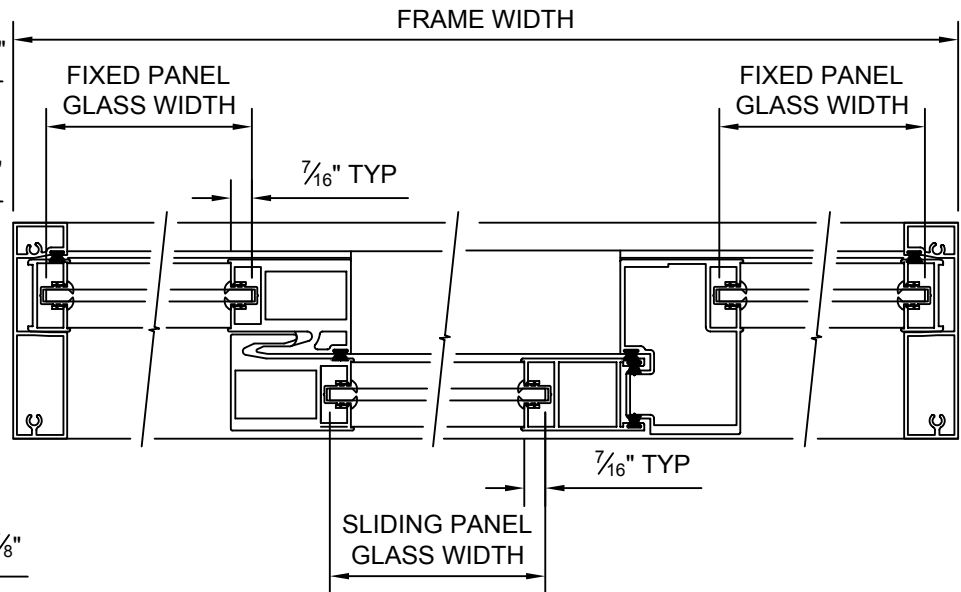

MAXIMUM RANGE OXOX

$$\text{GLASS WIDTH FOR 1848 LATCH} = \frac{\text{FRAME WIDTH MINUS } 8\frac{7}{8}''}{4}$$

$$\text{GLASS WIDTH FOR MS HOOKBOLT} = \frac{\text{FRAME WIDTH MINUS } 9\frac{3}{8}''}{4}$$

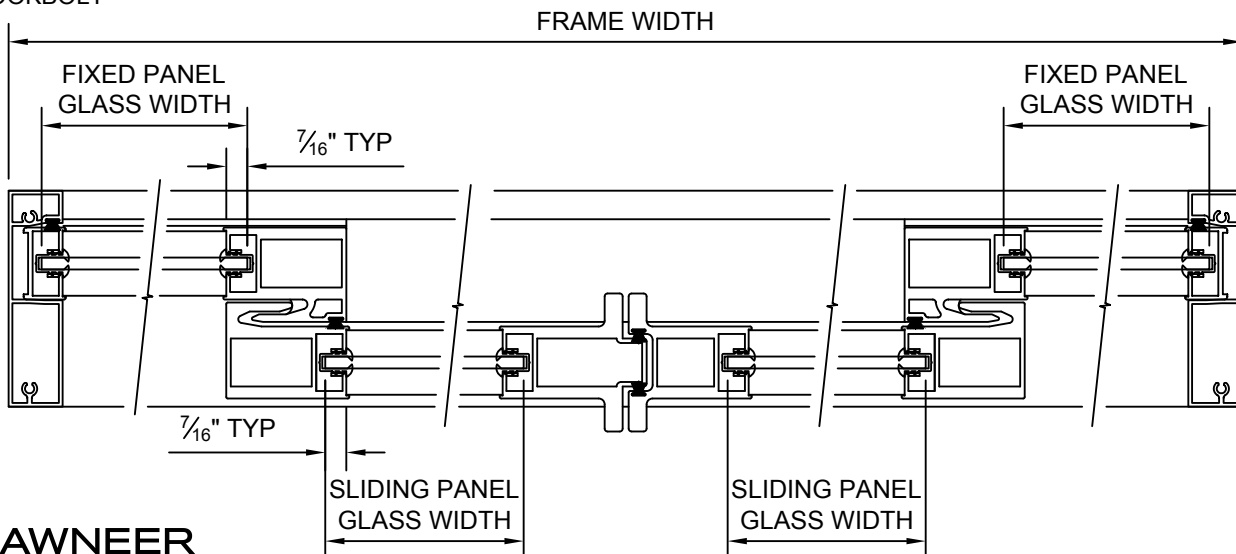

Laws and building and safety codes governing the design and use of glazed entrance, window, and curtain wall products vary widely. Kawneer does not control the selection of product configurations, operating hardware, or glazing materials, and assumes no responsibility therefor.

Kawneer reserves the right to change configuration without prior notice when deemed necessary for product improvement.
© Kawneer Company, Inc., 2009

- 1) Layout and identify all frame parts as shown in Parts Identification Table.
- 2) Using two (2) #128-267 screws per joint fasten head and sill to jambs as shown. On OXO units, install lock stile mullion to head and sill with two (2) #128-267 screws per end. Seal all frame joints with Tremco small joint sealant or equivalent.
- 3) Light Lock Stile Mullion shown on OXO unit, Medium Lock Stile Mullion similar. Heavy Lock Stile Mullion is not fastened to frame. Seal Lock Stile Mullion to sill as well as fasteners. Heavy Lock Stile Mullion requires NO SEALANT between itself and the sill.

NOTE:
IF WAX WAS USED TO INSTALL THE FASTENERS, IT SHOULD BE REMOVED PRIOR TO APPLYING SEALANT TO THE FASTENER HEADS.

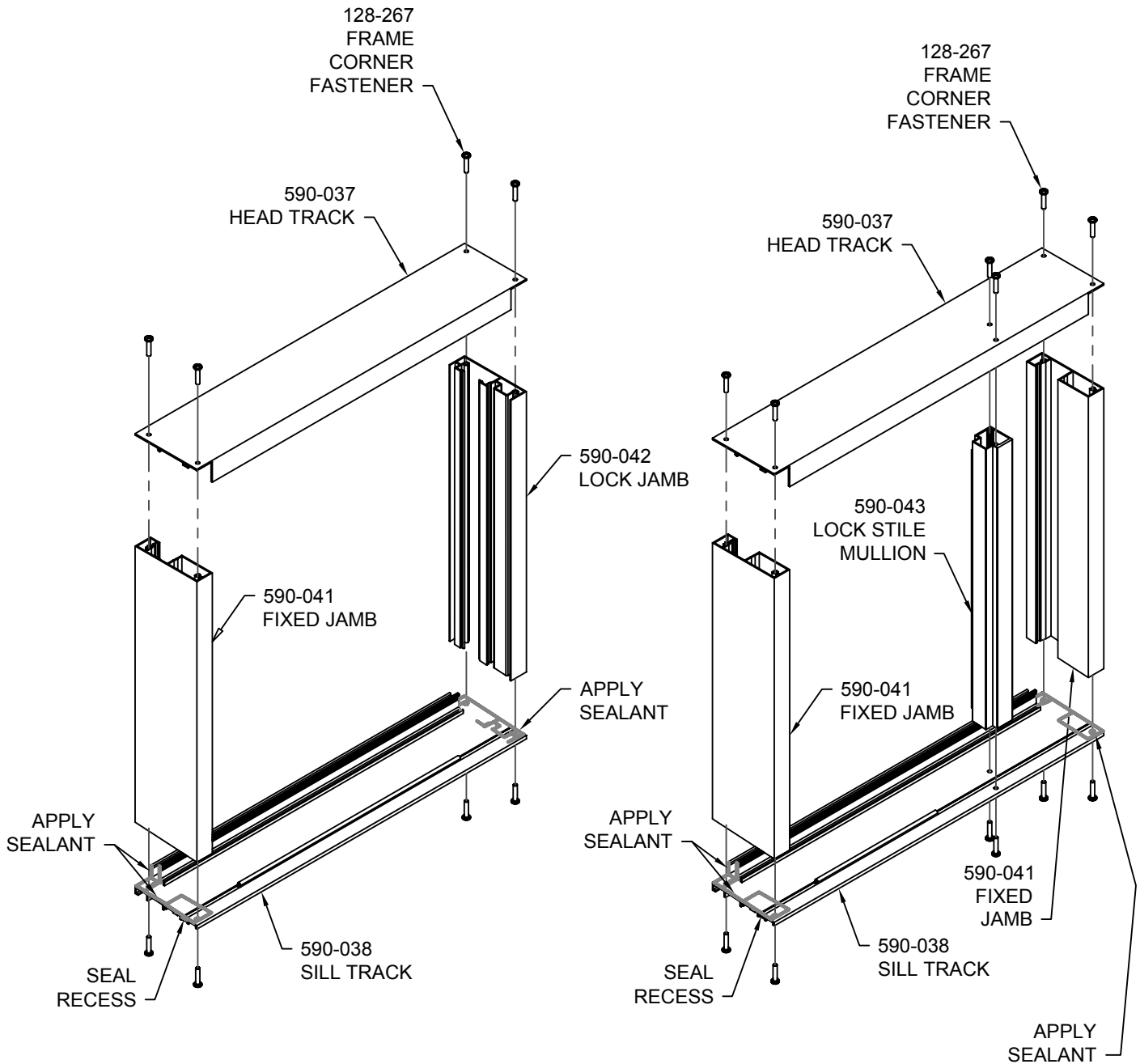

**OX FRAME
 (XO - REVERSE
 FIXED/LOCK JAMBS)**

**OXO-L FRAME
 (OXO-R - REVERSE
 LOCK STILE MULLION)
 (OXO SIMILAR WITHOUT LOCK STILE MULLION)**

Laws and building and safety codes governing the design and use of glazed entrance, window, and curtain wall products vary widely. Kawneer does not control the selection of product configurations, operating hardware, or glazing materials, and assumes no responsibility therefor.

Kawneer reserves the right to change configuration without prior notice when deemed necessary for product improvement.

© Kawneer Company, Inc., 2009

STEP 1:

Check the prepared opening. Make sure that the opening dimensions are correct for the unit being installed and that the opening is square and plumb before proceeding with the installation. A minimum of 3/8" clearance is recommended around all sides of the frame for shims and perimeter caulk joints.

STEP 2:

Place the assembled frame into the prepared opening in a bed of sealant (shown below) and loosely fasten head with a screw **NBK**.

STEP 3:

Shim and level sill. Be sure sill is shimmed properly to support the weight of the door panels. Insert and tighten screws (**NBK**) in prepared holes to anchor sill, making sure to put sealant on fastener threads.

STEP 4:

Shim and plumb jambs. Insert screws (**NBK**) in prepared holes and tighten, being sure to put sealant on fastener threads.

STEP 5:

Seal the entire interior and exterior perimeters with sealant.

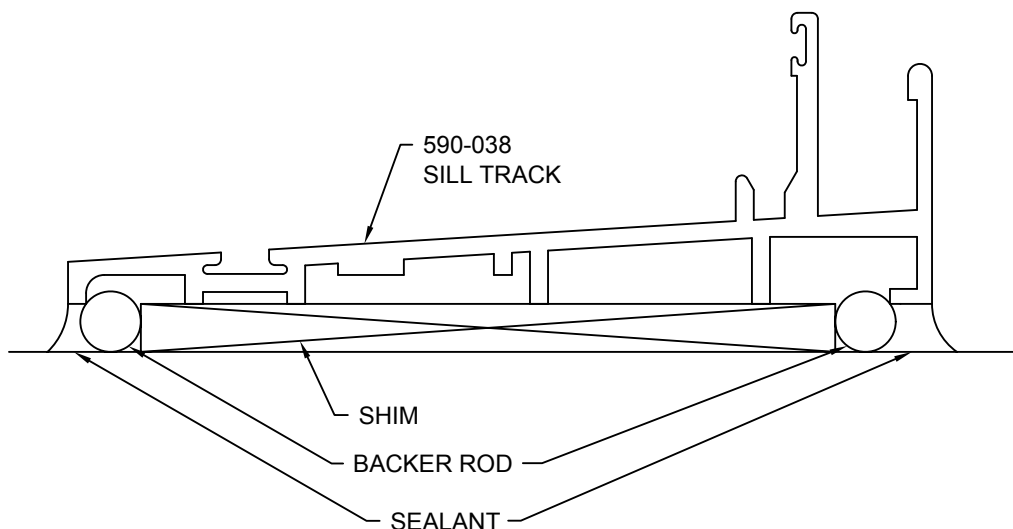
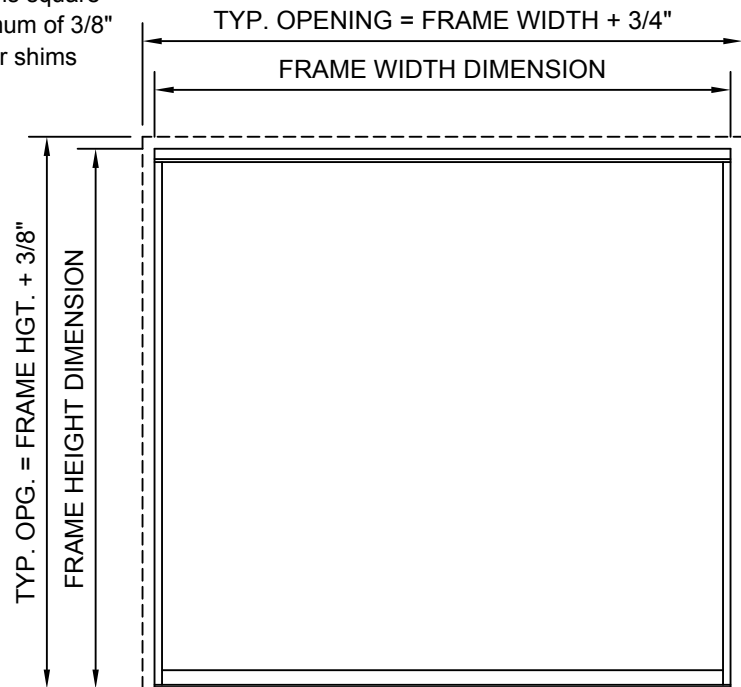

Laws and building and safety codes governing the design and use of glazed entrance, window, and curtain wall products vary widely. Kawneer does not control the selection of product configurations, operating hardware, or glazing materials, and assumes no responsibility therefor.

Kawneer reserves the right to change configuration without prior notice when deemed necessary for product improvement.
© Kawneer Company, Inc., 2009

STEP 1:

Once the frame is installed into the opening, the Lock Jamb Filler Plate should be installed. The Filler Plate should be held at an angle and the end cut at an angle should be inserted at the Sill.

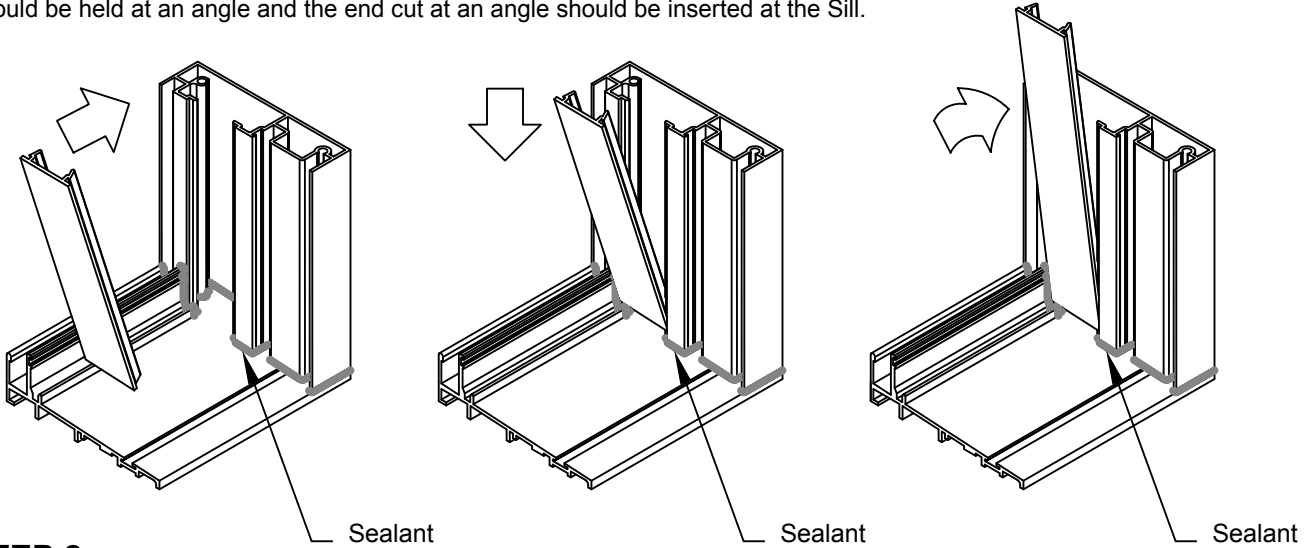

STEP 2:

Once the bottom of the Filler Plate is seated in the sill the middle and top should be rotated and snapped into the Lock Jamb.

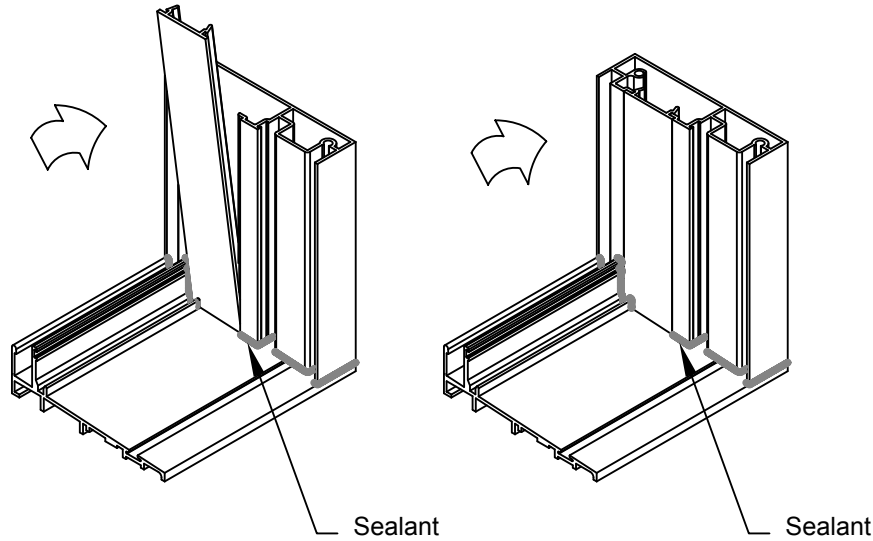

STEP 3:

The seam at the Lock Jamb Filler Plate and the Lock Jamb should be sealed.

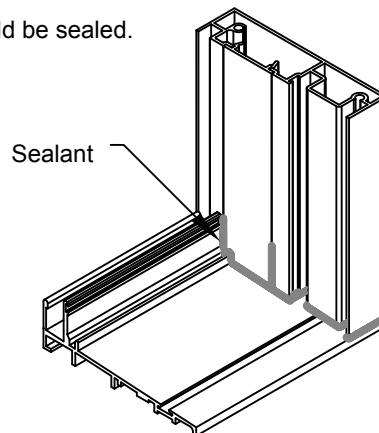

Laws and building and safety codes governing the design and use of glazed entrance, window, and curtain wall products vary widely. Kawneer does not control the selection of product configurations, operating hardware, or glazing materials, and assumes no responsibility therefor.

Kawneer reserves the right to change configuration without prior notice when deemed necessary for product improvement.
© Kawneer Company, Inc., 2009

STEP 1:

Starting at the top center of the glass, clamp one end of the glazing channel to the glass to temporarily hold it in place. Make sure that the end of the glazing channel is square cut. Wrap the glazing channel around the glass, cutting the corners as shown below. Stretch the glazing channel 2" on the sides and 1" on the bottom prior to cutting each corner. Square cut the glazing channel to the appropriate length to create a butt joint at the top of the glass. Remove the clamp and tape the two end of the glazing channel together to prevent them from separating during panel assembly. **If insulating or laminated glass is used, provide weep holes in the channel gasket as shown at 1/6 points of the bottom rail.**

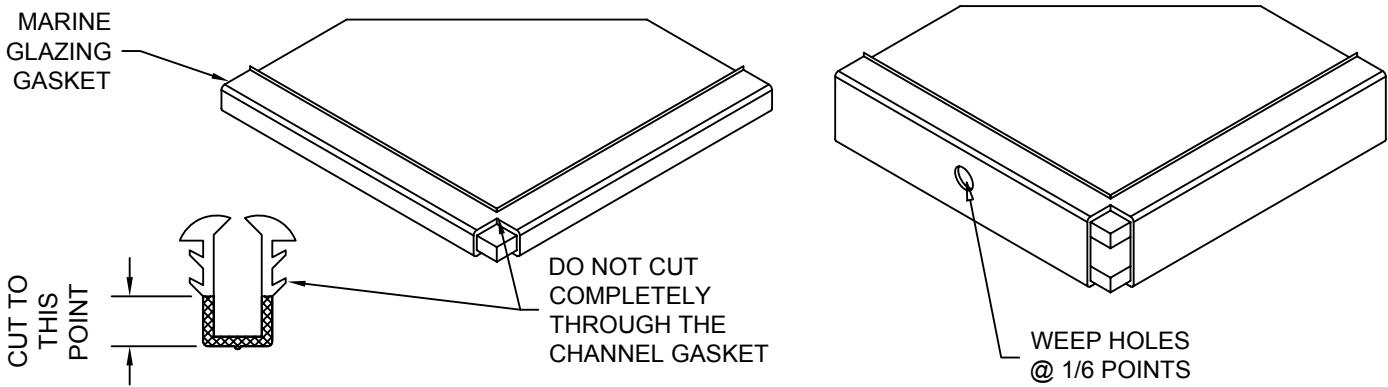

STEP 2:

On units with Insulated Glass install adhesive backed setting blocks 2" in from each end.

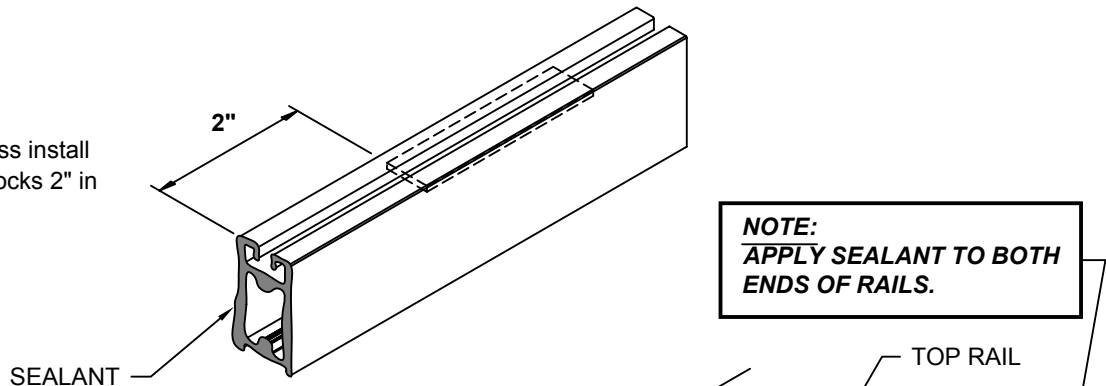

STEP 3:

Center the top and bottom rails into place over the gaskets. Use a rubber mallet or pipe/bar clamp to seat the rails on the glass and gaskets.

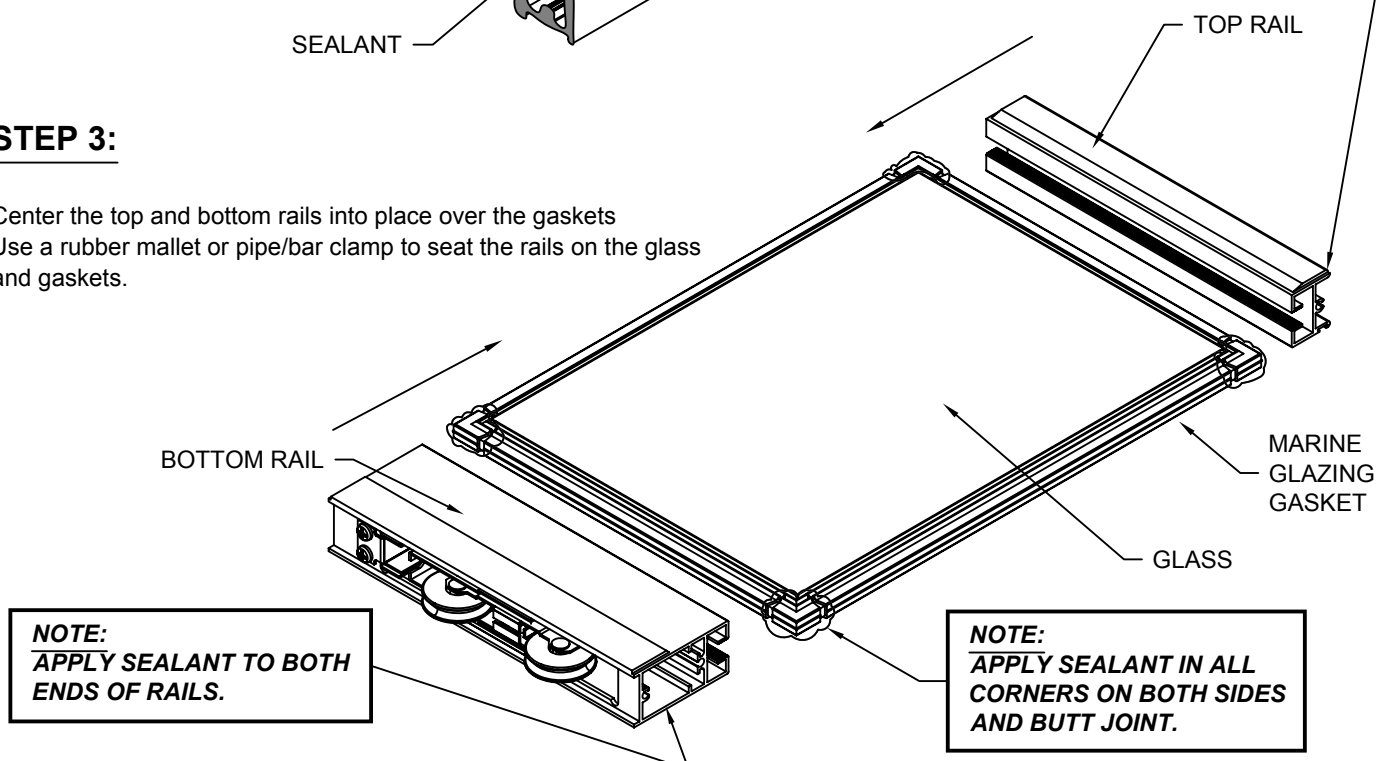

Laws and building and safety codes governing the design and use of glazed entrance, window, and curtain wall products vary widely. Kawneer does not control the selection of product configurations, operating hardware, or glazing materials, and assumes no responsibility therefor.

Kawneer reserves the right to change configuration without prior notice when deemed necessary for product improvement.
© Kawneer Company, Inc., 2009

STEP 4:

Install stiles in a similar manner, using a rubber mallet (or pipe/bar clamp) to seat the stiles on the glass and gaskets at all points. Using the panel corner fasteners and reinforcement plates, fasten top and bottom rails to stiles. Top and bottom rails must lock inside vertical stile dovetails.

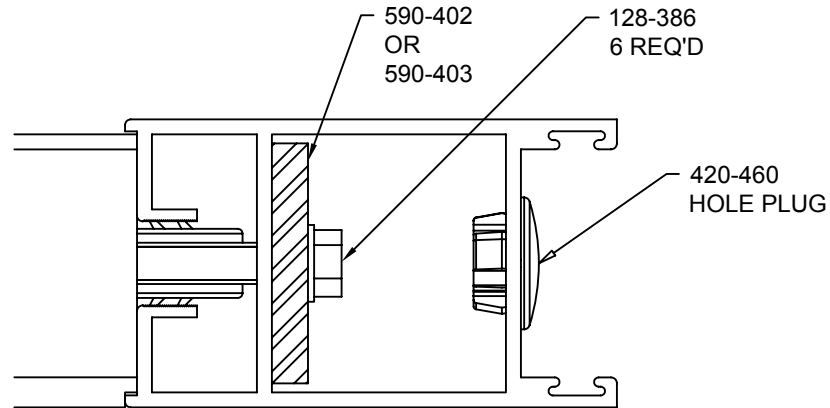

STEP 5:

Check squareness of panel.

STEP 6:

Install hole plugs in all panels except top hole of interlock.

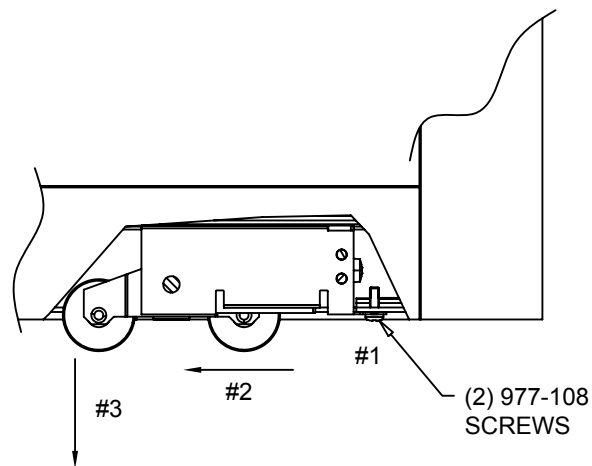

NOTE:

Casters are shipped installed in bottom rail. For replacement, remove screws (1), slide caster back (2), then pull out (3).

Laws and building and safety codes governing the design and use of glazed entrance, window, and curtain wall products vary widely. Kawneer does not control the selection of product configurations, operating hardware, or glazing materials, and assumes no responsibility therefor.

Kawneer reserves the right to change configuration without prior notice when deemed necessary for product improvement.

© Kawneer Company, Inc., 2009

STEP 1:

Place glazed sliding panel on work bench with exterior side down.

STEP 2:

Use mallet to install knurled barrel nuts into exterior pull.

NOTE: WHEN CYLINDER IS USED, SLIDE CYLINDER INTO THE CYLINDER RETAINER. POSITION THIS SUB-ASSEMBLY INTO THE RETAINING LEGS OF THE PULL (FIG B.). STAKE IN PLACE

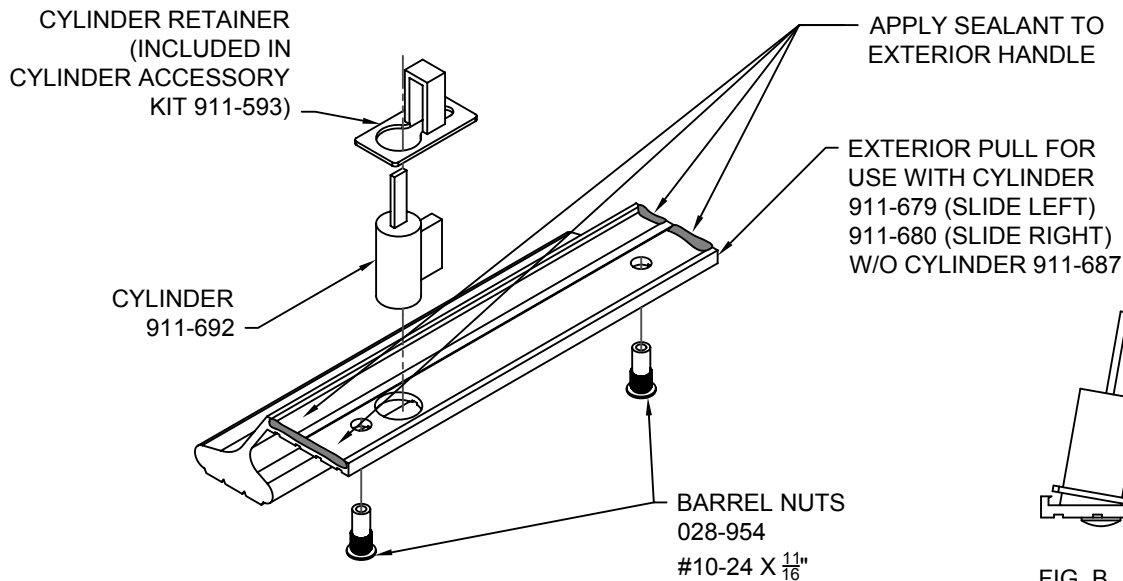
**STEP 1:**

Position exterior pull on stile.

NOTE: WHEN CYLINDER IS USED, POSITION WASHER, HUB RETAINER, AND CYLINDER HUB ON CYLINDER TAILPIECE. CHECK TO SEE IF CYLINDER TAILPIECE PROJECTS THRU CYLINDER HUB. IF IT DOES, SHORTEN TAILPIECE SO IT IS FLUSH WITH HUB.

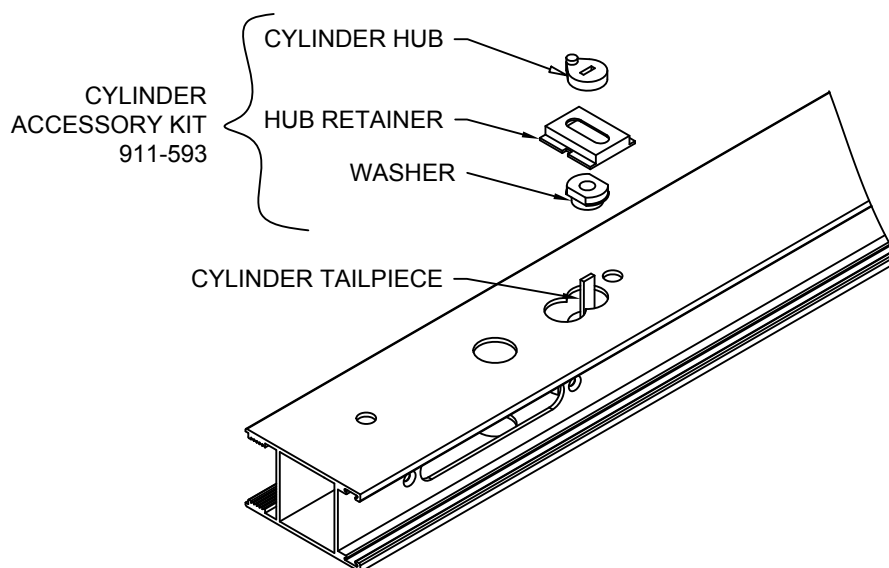

Laws and building and safety codes governing the design and use of glazed entrance, window, and curtain wall products vary widely. Kawneer does not control the selection of product configurations, operating hardware, or glazing materials, and assumes no responsibility therefor.

Kawneer reserves the right to change configuration without prior notice when deemed necessary for product improvement.
© Kawneer Company, Inc., 2009

STEP 4:

Position slide operator on stile, insert mounting screws into center hole and tighten - note location of mounting screws in slide operator.

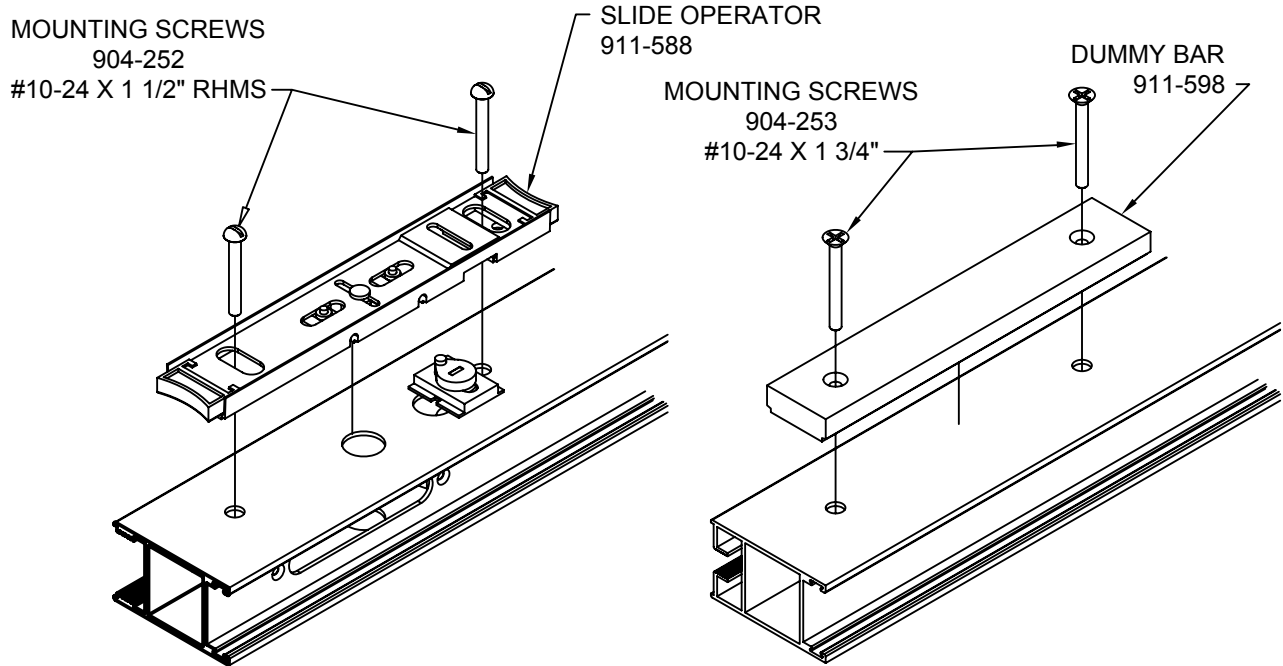

ACTIVE
(ON ALL UNITS)

IMPORTANT
PUSH SLIDE OPERATOR
TOWARDS GLASS WHILE
TIGHTENING DOWN
MOUNTING SCREWS

INACTIVE
(ON OXO UNIT)

STEP 5:

Slide interior pull over slide operator. Insert and tighten set screws until flush with pull.

(CAUTION: Do not overtighten)

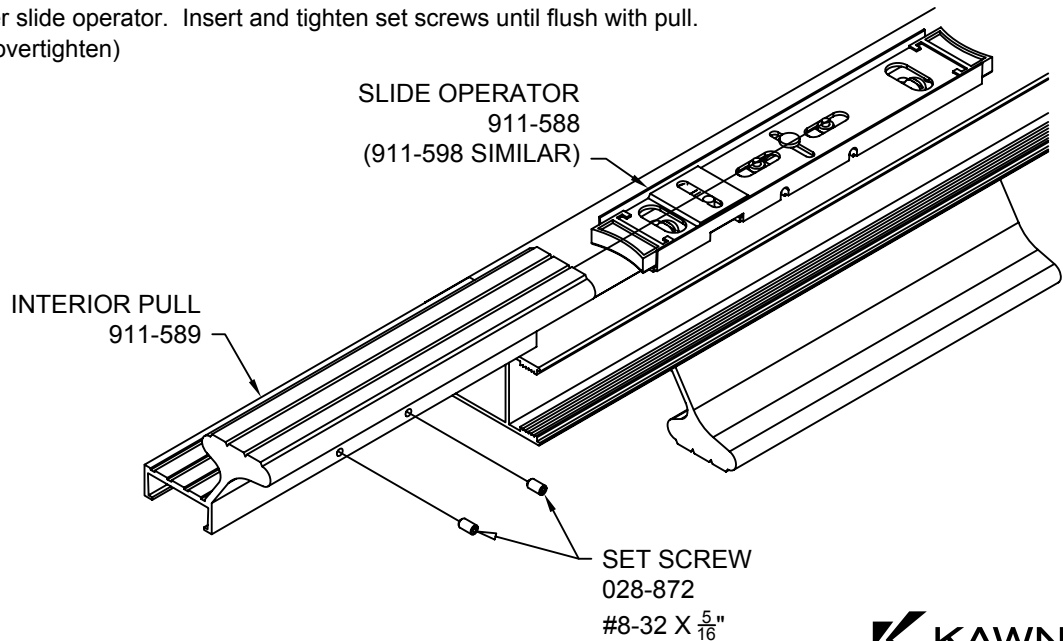

Laws and building and safety codes governing the design and use of glazed entrance, window, and curtain wall products vary widely. Kawneer does not control the selection of product configurations, operating hardware, or glazing materials, and assumes no responsibility therefor.

Kawneer reserves the right to change configuration without prior notice when deemed necessary for product improvement.
© Kawneer Company, Inc., 2009

STEP 1:

Place glazed sliding panel on work bench - exterior side down.

STEP 2:

Use mallet to pound knurled barrel nuts into exterior pull.

NOTE: WHEN CYLINDER IS USED, PLACE CYLINDER IN HOUSING ON EXTERIOR PULL. CHECK PROPER POSITION OF KEY SLOT BY INSERTING KEY. KEY SLOT MUST BE IN THIS POSITION WHEN PULL IS INSTALLED.

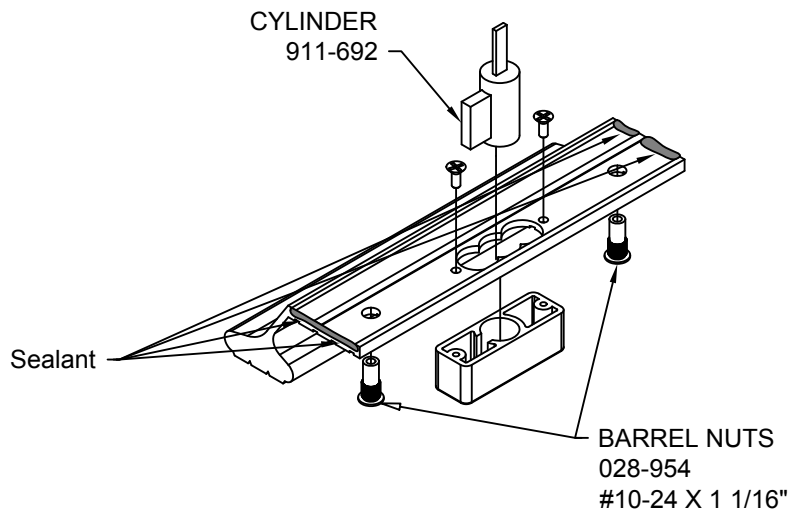
**STEP 3:**

Position exterior pull on stile.

STEP 4:

Position interior pull on stile. Insert and tighten mounting screws.

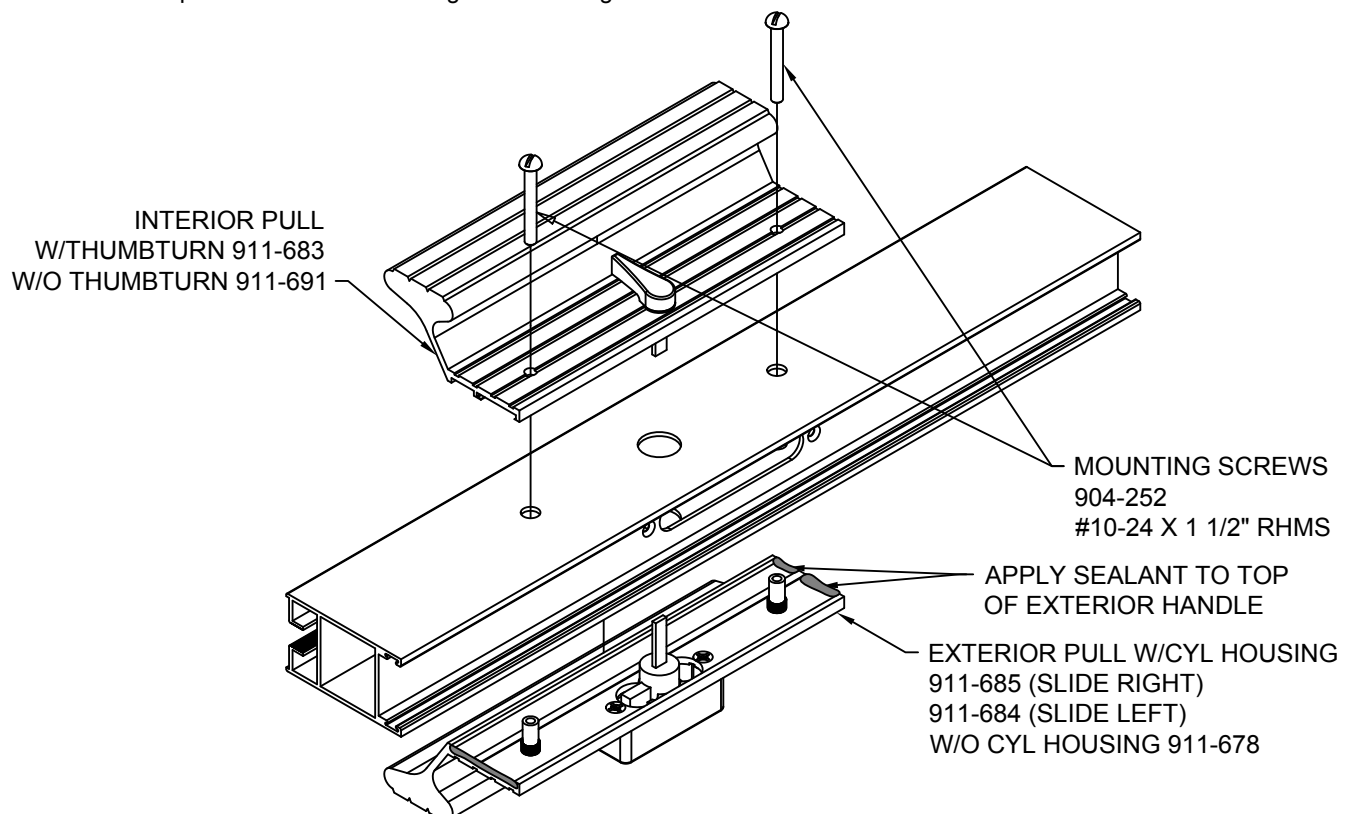

STEP 1:

Install fixed panels in frame by pushing up into head from outside. Swing bottom over sill and lower unit onto sill. Check position of seal in bottom rail.

SWING BOTTOM OVER SILL

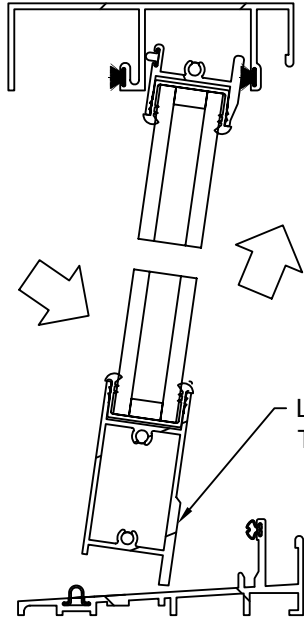

LOWER UNIT

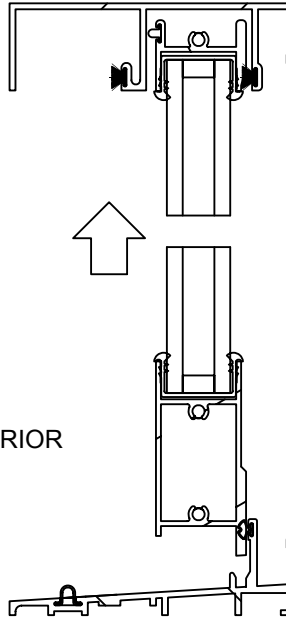

POSITION

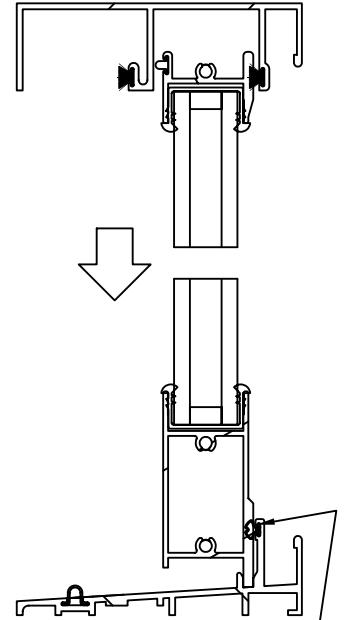

LONGER LEG TOWARD INTERIOR

CHECK SEAL AT BOTTOM RAIL
THIS SEAL SHOULD RUN
APPROXIMATELY $\frac{1}{8}$ " - $\frac{3}{16}$ " LONG
EACH SIDE

STEP 2:

Push fixed panel tightly into jamb.

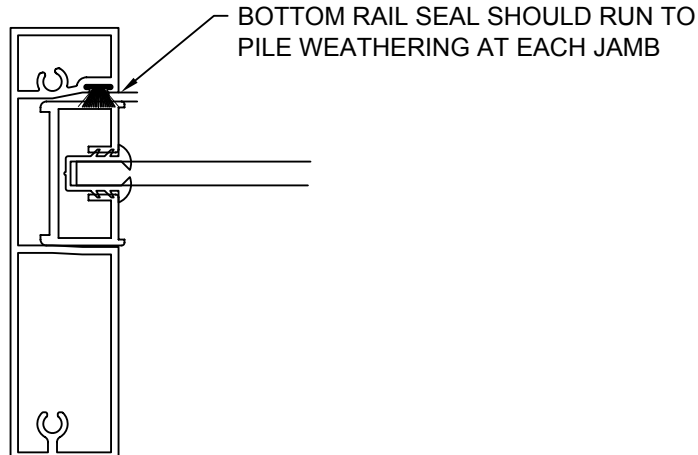

Laws and building and safety codes governing the design and use of glazed entrance, window, and curtain wall products vary widely. Kawneer does not control the selection of product configurations, operating hardware, or glazing materials, and assumes no responsibility therefor.

Kawneer reserves the right to change configuration without prior notice when deemed necessary for product improvement.

© Kawneer Company, Inc., 2009

STEP 3:

Anchor fixed panel clip 590-401 to head with #028-514 screw, clip will be used in lieu of hole plug (See Fig. A). Seal as shown.

STEP 4a:

When fixed panel is secured, set 590-985 air dam as shown by Fig. A.

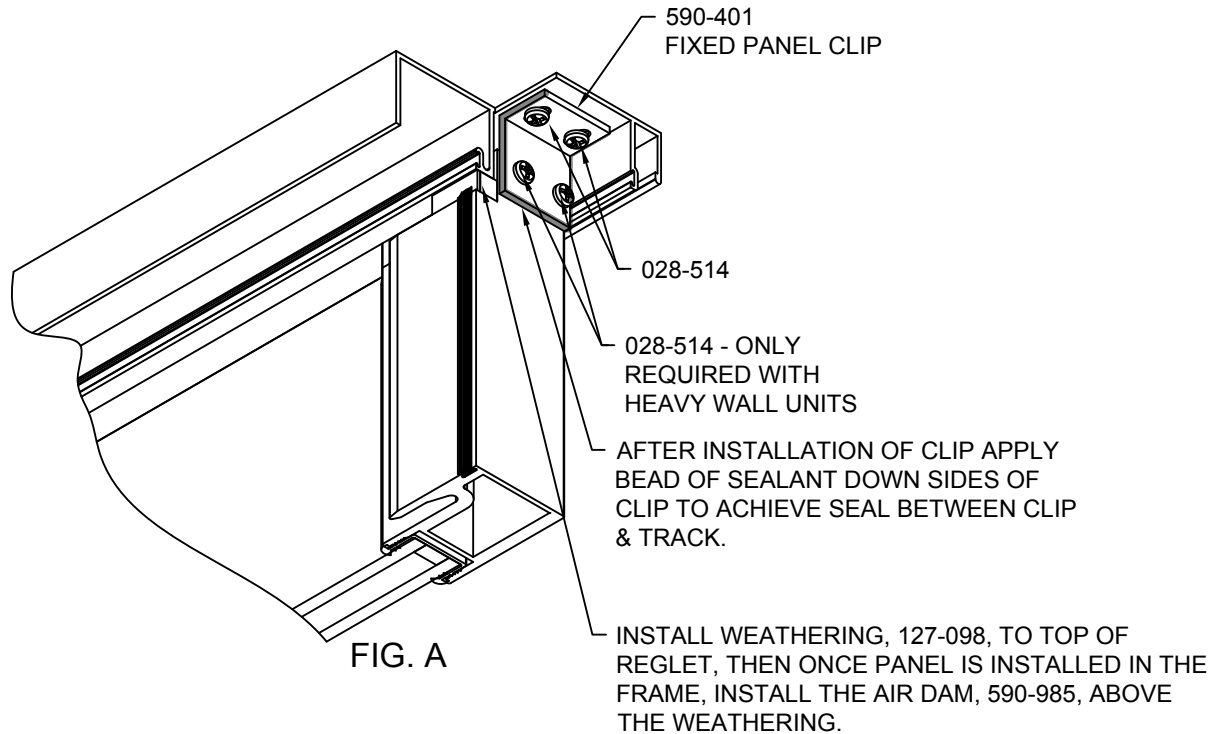

**NOTE:
DO NOT APPLY
SEALANT TO
THIS AREA!**

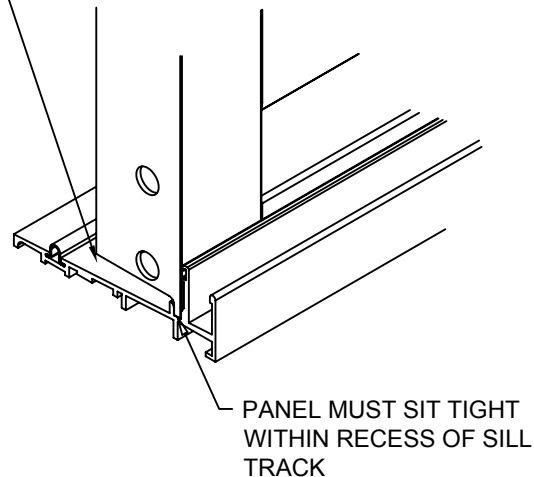

Laws and building and safety codes governing the design and use of glazed entrance, window, and curtain wall products vary widely. Kawneer does not control the selection of product configurations, operating hardware, or glazing materials, and assumes no responsibility therefor.

Kawneer reserves the right to change configuration without prior notice when deemed necessary for product improvement.
© Kawneer Company, Inc., 2009

STEP 4b:

On Heavy Wall Units Mullion Reinforcement Angles must be installed on the Interlock Mullion

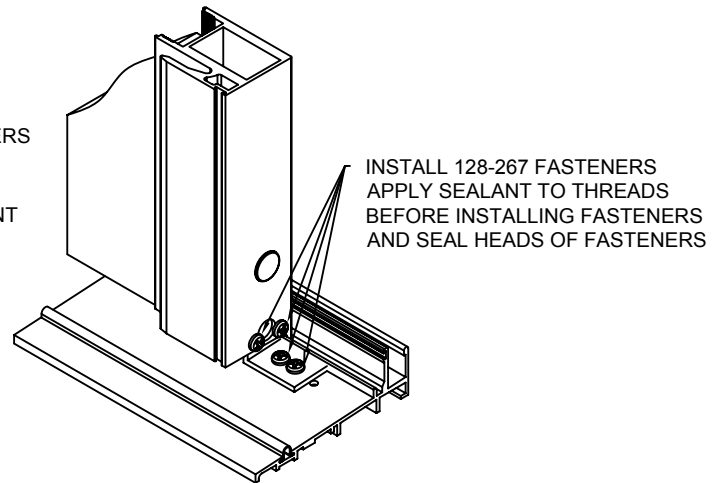
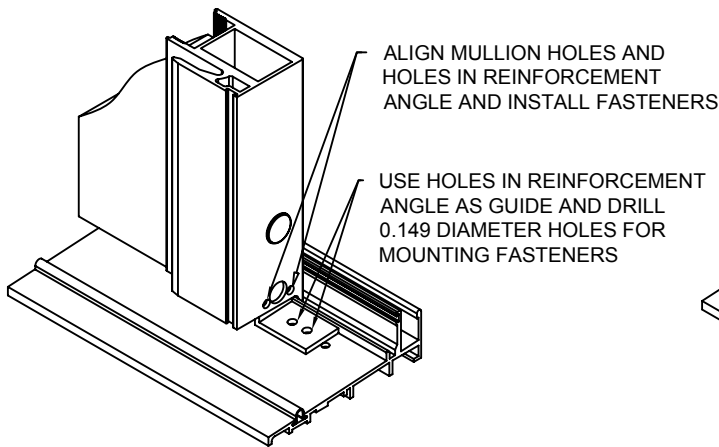
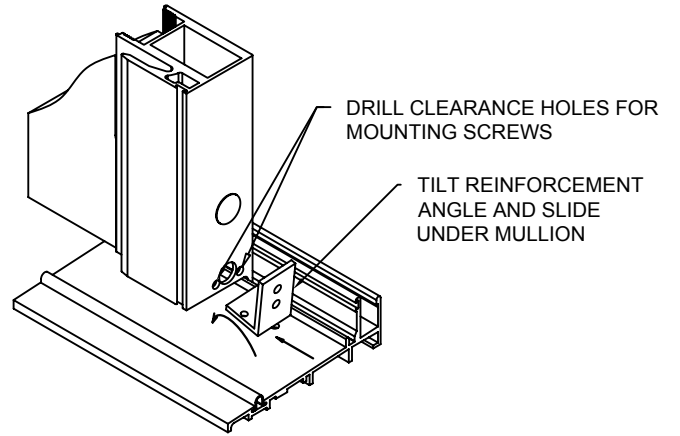
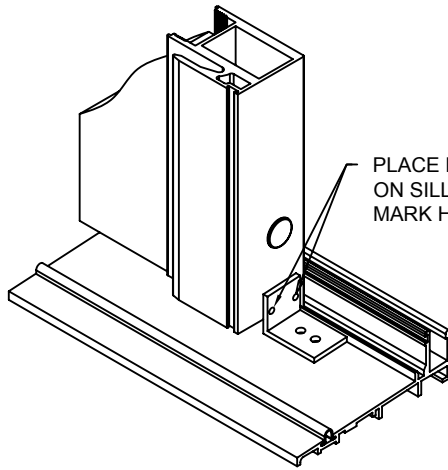

STEP 5:

On OXO Units, install #128-284 lock stile mullion retainer screw.

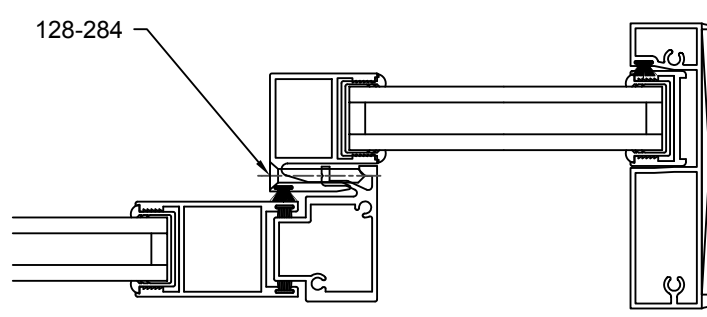

Laws and building and safety codes governing the design and use of glazed entrance, window, and curtain wall products vary widely. Kawneer does not control the selection of product configurations, operating hardware, or glazing materials, and assumes no responsibility therefor.

Kawneer reserves the right to change configuration without prior notice when deemed necessary for product improvement.

© Kawneer Company, Inc., 2009

STEP 6:

Place sill adaptor across door opening and fasten with #128-284 screws.

APPLY CLEAR JOINT SEALANT AT BOTH ENDS

128-284 AS REQUIRED
PUMP SEALANT INTO SCREW
HOLE AND ONTO THREADS

HORIZONTAL PILE WEATHERING
SHOULD EXTEND 1/8"-3/16" PAST
EACH END OF SILL ADAPTER

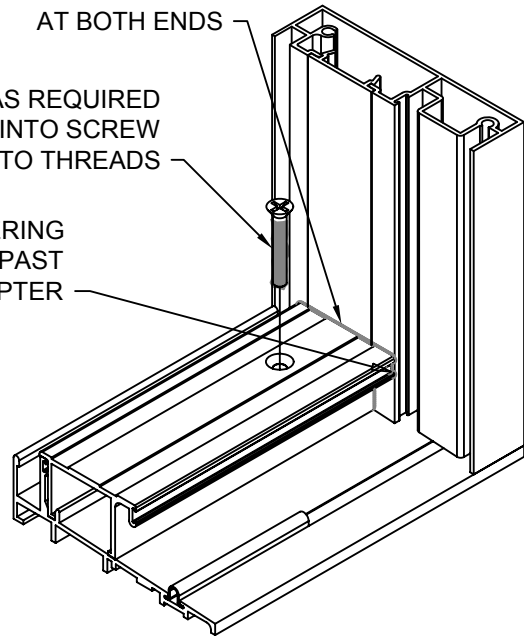

STEP 7:

Install sliding panel from outside similar to fixed panel. Make sure the larger build-out on the sliding bottom rail is to the interior.

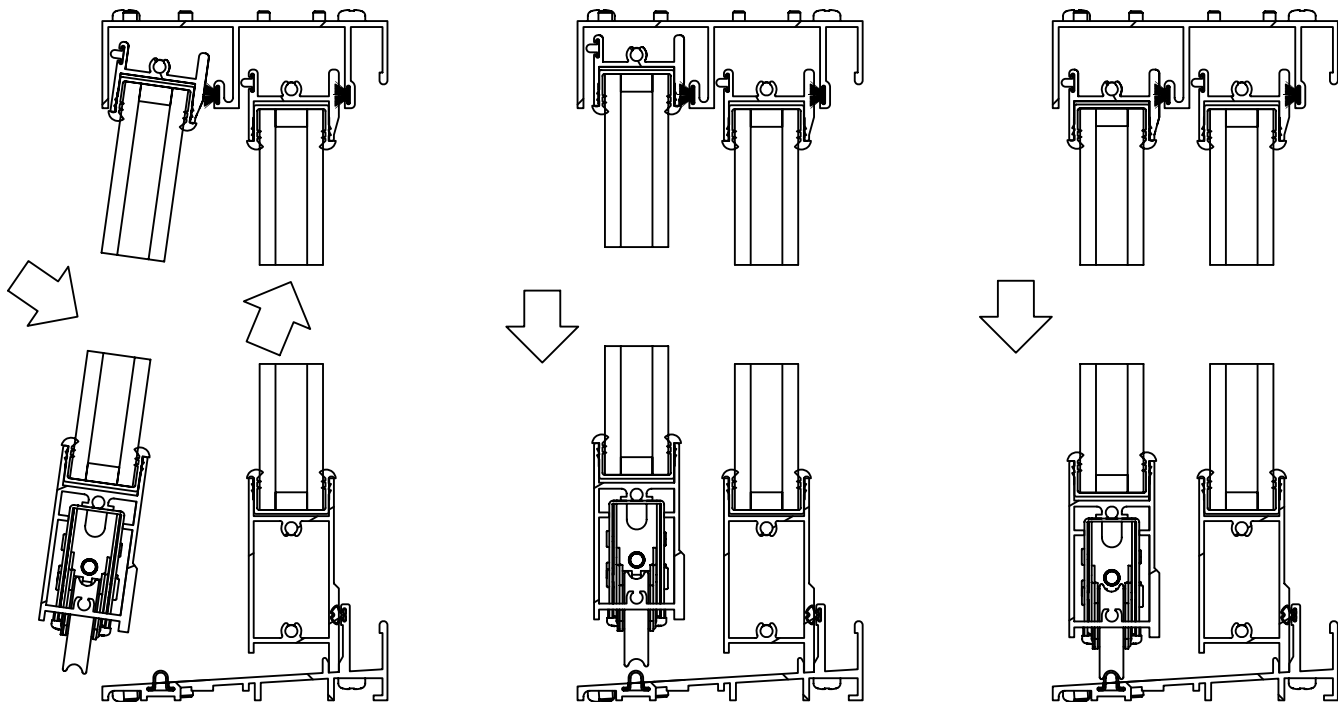

Laws and building and safety codes governing the design and use of glazed entrance, window, and curtain wall products vary widely. Kawneer does not control the selection of product configurations, operating hardware, or glazing materials, and assumes no responsibility therefor.

Kawneer reserves the right to change configuration without prior notice when deemed necessary for product improvement.
© Kawneer Company, Inc., 2009

STEP 8:

Make sure rollers seat on track. Adjust rollers to align panel with fixed interlock stile (and meeting stiles on OXXO units) and to provide a smooth sliding action. Turn adjusting screw (thru hole in both stiles below top spline screw) clockwise to raise unit - counterclockwise to lower unit.

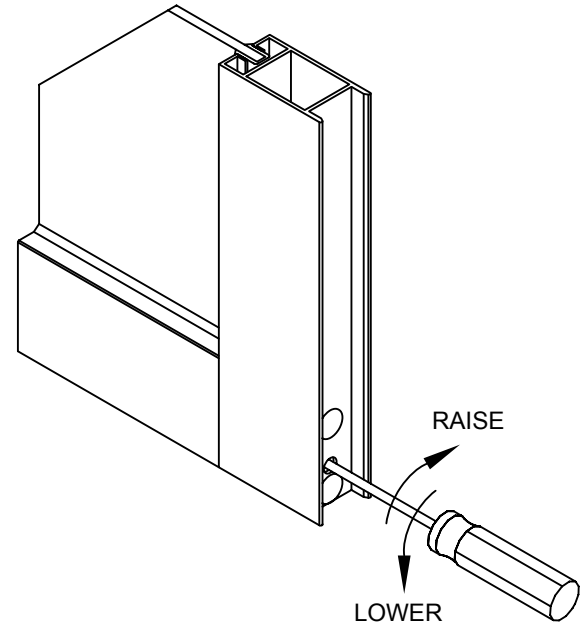

STEP 9:

Adjust lock.

For 1848 Hookbolt Lock:

- A. Loosen strike screws and adjust top of strike cut-out to approximately 1/32" above flat portion of hookbolt. NOTE: If strike cannot be adjusted to proper height, raise or lower rollers as required - panel must be realigned with fixed interlock, etc.
- B. Adjust hookbolt in or out as required to provide proper lock engagement and prevent movement of sliding panel when locked. Turn screw clockwise to extend, counterclockwise to retract.

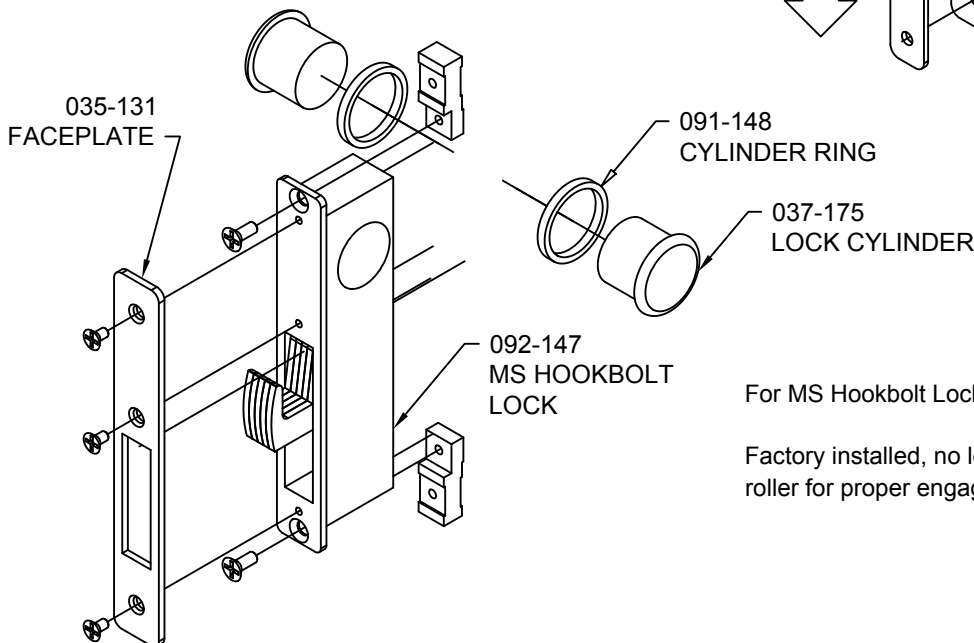
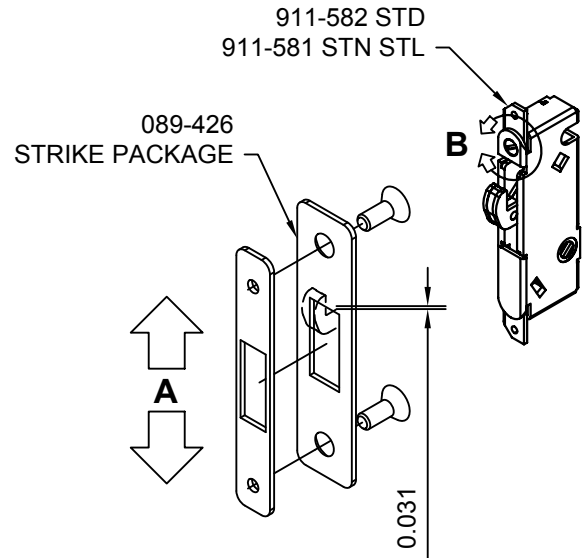

For MS Hookbolt Lock:

Factory installed, no lock adjustments. Adjust roller for proper engagement of hookbolt.

Laws and building and safety codes governing the design and use of glazed entrance, window, and curtain wall products vary widely. Kawneer does not control the selection of product configurations, operating hardware, or glazing materials, and assumes no responsibility therefor.

Kawneer reserves the right to change configuration without prior notice when deemed necessary for product improvement.

© Kawneer Company, Inc., 2009

STEP 10:

Locate and attach bumper #911-347 at head and sill with #128-271 screws (set sill bumper in a bed of sealant).

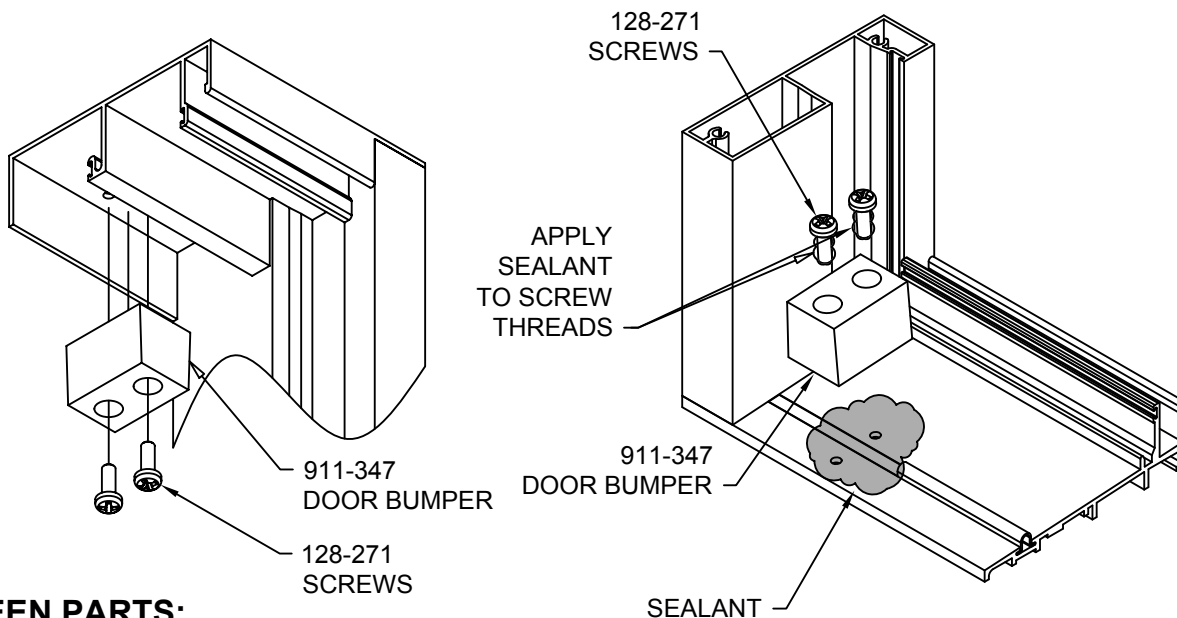
**SCREEN PARTS:**

Standard duty and heavy duty screen panels are shipped with rails fully assembled and other parts necessary for installation including pull handle, top/bottom rollers, strike and optional panel components such as reinforcing cross bars and astragal. Typical cross sections are shown below.

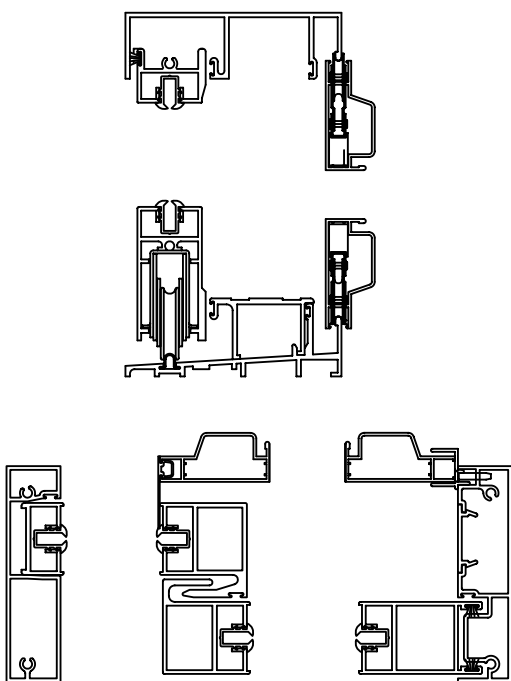
**SCREEN SIZE FORMULAS:**

$$\text{Height} = \text{Lite Opening} + 3.407''$$

OX / XO & OXO

Std- & Mid- Range

$$\text{w/1848 Locks} = \text{Lite Opening} + 3.750''$$

$$\text{w/MS Locks} = \text{Lite Opening} + 4.250''$$

High- Range

$$\text{w/1848 Locks} = \text{Lite Opening} + 4.500''$$

$$\text{w/MS Locks} = \text{Lite Opening} + 5.000''$$

OXXO

Std- Range

$$\text{w/1848 Locks} = \text{Lite Opening} + 4.094''$$

$$\text{w/MS Locks} = \text{Lite Opening} + 4.344''$$

Mid- Range

$$\text{w/1848 Locks} = \text{Lite Opening} + 4.344''$$

$$\text{w/MS Locks} = \text{Lite Opening} + 4.563''$$

High- Range

$$\text{w/1848 Locks} = \text{Lite Opening} + 5.313''$$

$$\text{w/MS Locks} = \text{Lite Opening} + 5.313''$$

Laws and building and safety codes governing the design and use of glazed entrance, window, and curtain wall products vary widely. Kawneer does not control the selection of product configurations, operating hardware, or glazing materials, and assumes no responsibility therefor.

Kawneer reserves the right to change configuration without prior notice when deemed necessary for product improvement.
© Kawneer Company, Inc., 2009

STEP 1: Standard duty screen - typical OX and XO installation.

From interior position top rollers on head screen track. Push screen into head, and swing bottom of screen into position, placing bottom rollers on sill screen track.

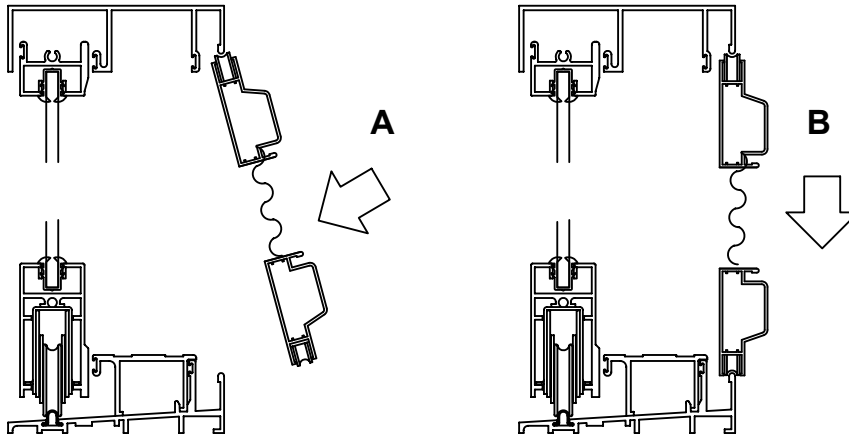

STEP 2:

Adjust bottom rollers to align screen with interlock stile and adjust top rollers to provide for smooth sliding operation.

STEP 3:

Locate and attach strike/keeper with latch.

STEP 4:

Check bug flap for proper contact and alignment.

SPECIAL INSTRUCTIONS FOR OXO SCREENS

- A. Follow steps A & B for Standard Screens.
- B. Match drill holes in screen interlock using #28 drill.
- C. Install screen interlock on fixed panel interlock with #028-288 screws.

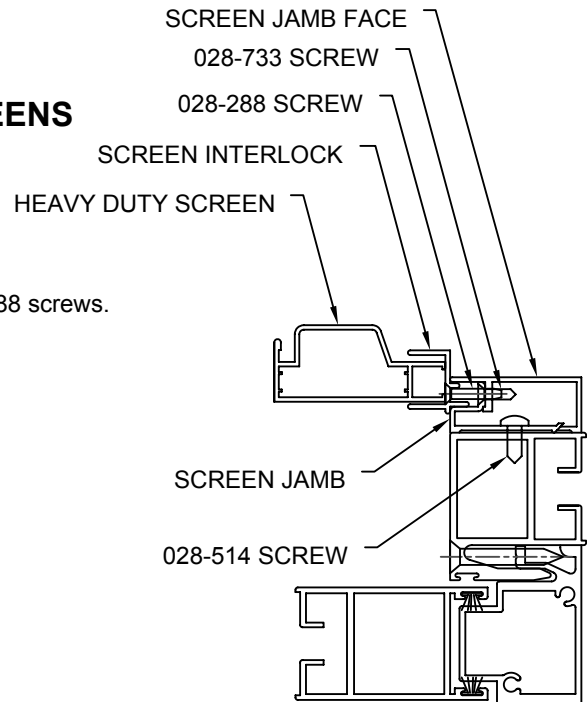

OXXO SCREEN STOP (590-330) IS TO BE LOCATED AT CENTERLINE OF DOOR FRAME AT HEAD AND SILL, ONLY ON OXXO UNITS

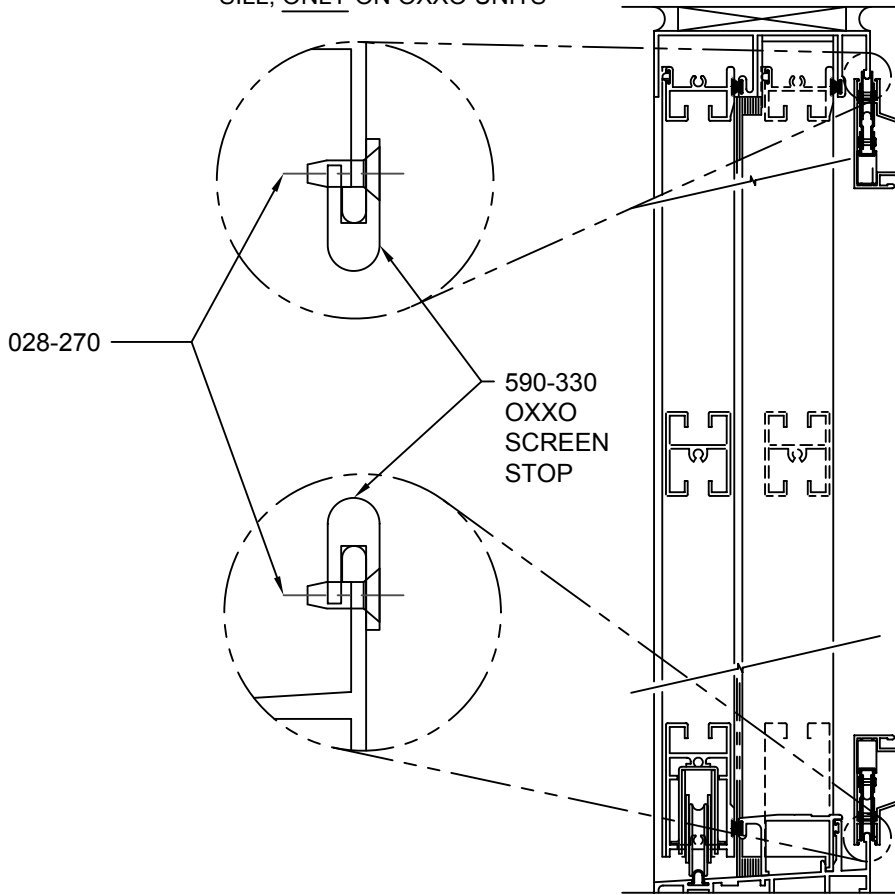

Laws and building and safety codes governing the design and use of glazed entrance, window, and curtain wall products vary widely. Kawneer does not control the selection of product configurations, operating hardware, or glazing materials, and assumes no responsibility therefor.

Kawneer reserves the right to change configuration without prior notice when deemed necessary for product improvement.
© Kawneer Company, Inc., 2009

Laws and building and safety codes governing the design and use of glazed entrance, window, and curtain wall products vary widely. Kawneer does not control the selection of product configurations, operating hardware, or glazing materials, and assumes no responsibility therefor.

Kawneer reserves the right to change configuration without prior notice when deemed necessary for product improvement.

© Kawneer Company, Inc., 2009

Laws and building and safety codes governing the design and use of glazed entrance, window, and curtain wall products vary widely. Kawneer does not control the selection of product configurations, operating hardware, or glazing materials, and assumes no responsibility therefor.

Kawneer reserves the right to change configuration without prior notice when deemed necessary for product improvement.

© Kawneer Company, Inc., 2009

Laws and building and safety codes governing the design and use of glazed entrance, window, and curtain wall products vary widely. Kawneer does not control the selection of product configurations, operating hardware, or glazing materials, and assumes no responsibility therefor.

Kawneer reserves the right to change configuration without prior notice when deemed necessary for product improvement.

© Kawneer Company, Inc., 2009



**KAWNEER COMPANY, INC.
TECHNOLOGY PARK/ATLANTA
555 GUTHRIDGE COURT
NORCROSS, GEORGIA 30092**